



## **The Stucco Institute**

Stucco Information, Design, Application and  
Repair Protocols for Stucco Applicators  
[www.stuccoinstitute.com](http://www.stuccoinstitute.com)

# **Sealed Cladding System Design and Installation Manual SCS - 01**

Stucco Institute  
Robert Koning - Director  
8301 Joliet Street  
Hudson, Florida 34667  
727-857-3904  
[Info@stuccoinstitute.com](mailto:Info@stuccoinstitute.com)

All material Copyrighted 2015 - 2019

Applicable for all Climate Zones  
Critical for Proper Cladding Performance in  
Code Climates Zones 1, 2 and 3  
[Florida Product Approval #FL30710-R1](#)

## FOREWARD

Application of exterior cement wall plastering in Florida has been successfully performed over both wood framed (metal lathed) and Concrete Masonry Units (CMU's a/k/a "Block") wall construction since the inception of stucco itself.

Historically, the application process was systematically taught to the tradesmen—then methodically applied to countless numbers of homes over many decades - performing without any mentionable faults or failures. That success, however, was (and is) interdependent upon other tradesmen performing their work accurately and professionally—it is a systemic process.

I have personally been involved with thousands of these applications for over 40 years and know of thousands more performed by plastering associates and predecessors. All of these are still in service today, and many of these "old-time" applications are still being quietly applied by knowledgeable stucco tradesmen without any of the problems occurring with the more modern adapted "drain-plane" systems such as; excessive cracking, blow outs, wall leakage, and substrate decay.

For an understanding of these systems and their methodologies refer to the educational resources found at [www.stuccoinstitute.com](http://www.stuccoinstitute.com).

The Sealed Cladding System is not a new stucco system - quite the contrary - its is a very old system, performing successfully for over a century. Its current form simply reflects improvements in lath (Structalath) and Coatings (Drylok Extreme) and has been issued product approval.

The Sealed Cladding System has full Florida Product Approval ([#FL30710-R1](#)) and all required components such as the Fenestration De-

tails (Section 06 in the Details Series) have individual compliance with the ASTM E330 & E331 assuring full code compliance with peripheral components.

The system components and details (including CAD downloads) have been designed to aid in the envelope plan submission requirements of Chapter 1 of the ICC and Florida Building Codes.

## MANUAL SEQUENCE

The Manual is broken into 10 Informational Chapters to aid in easy understanding of the Sealed Cladding System. Chapter 11 contains all details and drawings. The Appendices are informational as to related system components. Some content may be outside the plasterer's scope - but have been included so the plasterer may alert the contractor or designer of a questionable detail or condition.

## DEVELOPMENT ACKNOWLEDGMENTS

The Sealed Cladding System has been developed by the Stucco Institute with the aid and assistance from UGL - United Gilsonite Laboratories (Harry Lubitz) , Clark Dietrich Building Systems Structalath (Christopher Little), Typar (Bijan Mansouri), Second View Consulting (Jay Hester), and the herculean assistance of staff members Jeff Hyde, Jay and Mark Stevenson, Steven Wetzel, Rachel Doty, Norman Shuhart and John Dermott - all involved in discovering and repairing plastering and waterproofing deficiencies.

## POSTHUMOUS RECOGNITIONS

John Bucholtz whose common sense technical bulletins and commentary continue to inform and enlighten us - and James (Butch) Burney my Uncle and teacher. A finer plasterer never

graced a mud board or pulled a rod. His knowledge seemed instinctive, but was acquired, honed, and practiced through excellence of the profession - which he taught to us with patience and skill.

## SPECIAL RECOGNITIONS

Special thanks to:

- ◆ Jim Petersen, Steve Smith, Rick Hudak, and David Jarvis (Lennar Homes) for their input, suggestions and aid in field performance installations and testing.
- ◆ The patience and guidance of PRI Testing (Zach Priest) in guiding us through the testing, approval and certification processes.
- ◆ And my Texas plastering comrade, Mr. Tim



Rogan for his counsel and advice.

Please to refer to the Stucco Institute for publications and data related to other construction practices, details and defects that affect the performance of a building's envelope.

Thanks to all...

Robert Koning has been involved with the plastering, stucco, masonry, roofing and waterproofing industry for over 40 years.

The Koning family's involvement in the construction industry dates back to the 1920's. This history with construction's tried-and-true methods and developments provide a keen awareness when evaluating the efficacy of ever-advancing plastering products, methods, and standards.

He is director of the Contractors Institute, the Building Officials Institute and the Stucco Institute.

His numerous licenses and certifications include: Bachelor of Science in Construction Engineering – Certified Arbitrator & Mediator – Certified General, Building, Roofing, Plumbing, Underground Utilities, Air Conditioning contractor, Unlimited Master Electrician, Solar Contractor, Mold Assessor, Mold Remediator, Home Inspector, and BPI Building Analyst.

Robert Koning is a Code Certified: Level 1 – Building, Roofing, Plumbing, Mechanical, and Electrical Inspector; Level 2 -Building, Plumbing, Mechanical, and Electrical Plans Examiner; Level 3 – Chief Building, Plumbing, Mechanical and Electrical Code Analyst; Level 4 -Code Enforcement and Administration Professional; and State Certified Standard Building Code Administrator.

Chapter	Subject	Page Number
01	System Description	5
02	System Components	8
03	Building Wrap, Lath and Plaster	10
04	Determining Wall Pressures	13
05	Fastener Requirements and Patterns	19
06	Mixing and Proportions	30
07	"V" Grooves and Sealant Detailing	33
08	Corners	38
09	Control Joints	48
10	Coatings and Sealants	52
11	Details and Drawings (Index Page)	57
12	Appendix "A" - Manufacturers Information	82



## CHAPTER 01

### SYSTEM DESCRIPTION

- 1) The Sealed Cladding System® SCS-1.0 has been developed by the Stucco Institute to provide a serviceable cladding system for both residential and commercial construction applications.
- 2) This field developed system has served as a successful cladding system for over 75 years. It is different than the ASTM C-926 and C-1063 in that it is specific in its purpose and use. It uses a face barrier system rather than a drain plane mechanism for moisture management.
- 3) The Sealed Cladding System®, SCS-01, is approved pursuant to the Florida and ICC code requirements found at 1403.2 and R703.1.1 (reports downloadable at [sealedcladdingsystems.com](http://sealedcladdingsystems.com)) and has Florida Product Approval #FL30710-R1
- 4) From the approved wall substrate outward, the system is comprised of:
  - a. Typar® House Wrap
  - b. StructaLath®
  - c. Vinyl Corp® Accessories
  - d. Type "S" Portland Cement
  - e. Polyurethane Sealant
  - f. DRYLOK® Extreme Waterproof Coating
- 5) These products must be assembled in accordance with each manufacturer's instructions however the attachment, applications, detailing, coverage and other provisions of this manual must be strictly followed since they represent the basis for the system testing and product approval. These system details have been assembled from historic plastering knowledge that continues to yield successful cladding installations.
- 6) The specifications herein contain all information for building department plan submission / review pursuant to the requirements of FBC & ICC 107.2.4 Exterior wall envelope.
- 7) The Sealed Cladding System® is the only system that will withstand the service rigors of application in warm-humid areas defined in the International Energy Conservation Code, Figure 301.1, CLIMATE ZONES - 1, 2 and 3. Wall coverings in these areas are subject to high-wind tropical rainstorm events, hurricanes, humidity extremes and thermal shock during summer rainstorms, and oftentimes humidity containing high airborne salt concentrations. It performs in colder climate zones providing the same protection.
- 8) This Sealed Cladding System® provides for a waterproof cladding system when installed over structural panels such as Plywood or OSB, or DensGlas® (when used over steel framing) performing in all environments.
- 9) The system's exterior DRYLOK® Extreme coating and sealants provide the waterproofing intended to protect the structural panels, wood, wall and interstitial elements from bulk water infiltration.
- 10) The exterior DRYLOK® coating and sealants also prevent the passage and accumulation of excessive water vapor (Humidity) behind the cladding system, thereby preventing wholesale condensation caused from dew-point temperatures which are initiated by night time radiant heat losses to the open sky in addition to other initiating factors.

- 11) So successful is this system as a whole, that UGL, United Gilsonite Laboratories, (maker of DRYLOK®Extreme), will guarantee the waterproofing serviceability of the product when installed to these standards and per the manufacturer's installations on the Sealed Cladding System® for 15 years.
- 12) The system is not intended to be installed to provide structural shear or provide fire resistance values although cementitious claddings installed according to this standard may provide both.
- 13) When installed according to the requirements herein, this system provides a impermeable "Face-Barrier" system as described in ASTM 2128 and other publications.
- 14) The system is to be installed over a Typar® air/moisture housewrap. Typar® not only serves as an air/moisture barrier, but aids in maintaining moisture loss thereby aiding in controlled hydration during the cement's curing process.
- 15) The use of a separate bond breaker sheet applied over the Typar® is not required although one may be used if the building designer wishes.
- 16) No weep or drainage mechanism is necessary with this system since its application design prevents moisture entry at the system's face. The building designer may specify a foundation or mid-wall weep screed to serve as a plaster stop or to serve as a depth control screed. When specified for such application, they are not to be considered serving as a "weep" for a functioning drain plane.
- 17) Other premade accessories (if used) must follow the installation requirements of this document's provisions and details.
- 18) Venting mats or other "back-plane" venting strips, accessories or mechanisms are not permitted. Airborne salts and concentrations of high humidity can damage the system's performance. Some important considerations include the following:
  - a. Introduction and circulation of salt laden air behind the cladding's planar surface can cause condensation on sub-surfaces and lead to premature rusting of lath, fasteners and components.
  - b. High humidity accumulated behind the cement cladding can wet the back of the porous cladding material causing unintended expansion / contraction leading to fracturing and fungal contamination issues.
  - c. High humidity accumulated behind the cement cladding will cause expansion in structural wood panels serving as the substrate and induce stresses into the cladding system causing cracking and fracturing.
  - d. High humidity accumulated behind the cement cladding will aid in corrosion initiation of steel stud framing and tracks.
- 19) The forgoing conditions should be avoided at all costs. Therefore this system is dependent upon preventing moisture from gaining access to the system's components by simply blocking it at the system's face and by preventing movement of air by way of cavities or crevices' behind the wall cladding. This methodology has performed flawlessly for many, many decades.
- 20) Most plasterers find this system as a whole is installed with less effort than traditional

- 3 coat systems. The Structalath is less cumbersome than 2.5 expanded metal lath sheets. Costs are similar with a 3 coat system with the added bonus of providing a system that will remain free of defects serving as a permanent, durable, lifelong cladding to the owner. Since all application processes are spelled out in the accompanying text, there are no code "opinion" variables that can be applied by untrained and unknowledgeable consultants or home inspectors serving as a source for inaccurate report contentions or serving as accusations for frivolous litigation.
- 21) All exterior corners are recommended to be manually rodded. (See details). The system does not allow the use of premade plastic corner beads when wood or steel framing members are part of the substrate. Unless their flanges are "**fully and completely**" encased with wet cement plaster, they are ineffective and will contribute to wall leaks. Full encasement requires "working" wet plaster into each side of the bead's flanges. If this is done properly, the flange preparation requires more time and effort than simply "rodding" the corner which is the preferred method.
  - 22) Structalath itself may be cut and formed into external or internal corners provided each leg is 3" minimum or the lath may be folded around the corner 6" by itself.
  - 23) Structalath premade corner reinforcement is allowed but not required.
  - 24) All fenestration penetrations must be either isolated by a casing stop to form a joint or terminated into the product's extrusion meant to receive the cladding. Backer rods are used for large opening perimeters (See Chapter 11 Details). Alternatively, a sealant relief "V" kerf can be cut into the fresh cladding according to details provided herein (See Chapter 11 Details).
  - 25) With either methodology, an approved high grade polyurethane sealant must be applied and tooled into the joint or kerf.
  - 26) Coating must be of the specified type and applied to the correct mil thickness for each required coat.
  - 27) The system must be applied under the supervision of a "certified" technician having obtained designation; "CI-SCT".
  - 28) All certified technicians and their certification numbers are listed on the [www.sealedcladdingsystem.com](http://www.sealedcladdingsystem.com) website. Training is available on-line at the website.
  - 29) Plans submitted to building departments should bear the following information in their note section: "SCS-01 Sealed Cladding System" Installed according to the provisions of the [sealedcladdingsystem.com](http://sealedcladdingsystem.com)
  - 30) CI-SCT technicians shall furnish the owner, or post at the electrical panel box, an owner information placard outlining the owners responsibilities for maintenance and repair along with contact information.
  - 31) Placard can be downloaded from the website; [sealedcladdingsystem.com](http://sealedcladdingsystem.com).

**ONLINE TRAINING AND CERTIFICATION  
AVAILABLE FOR PLASTERING TRADESMEN,  
BUILDERS, PAINTERS, WATERPROOFERS  
SUPERINTENDENTS CODE OFFICIALS, ARCHITECTS,  
ENGINEERS OR DESIGNERS !**

**SEALEDCLADDING SYSTEM.COM**

## CHAPTER 02 SYSTEM COMPONENTS

- 1) Plywood: Minimum nominal 1/2-inch (12.5 mm) thickness with exterior glue is required for studs spaced a maximum of 16 inches on center. Plywood shall be installed in accordance with the Applicable Building Code and in accordance with American Plywood Association recommendations requiring 1/8-inch (3.2 mm) spacing between sheets at ends and sides.
- 2) Oriented Strand Board (OSB): OSB shall comply with specifications for Exposure 1, performance-rated panels in UBC Standard 23-3 (US DOC PS2-92), and shall have a minimum thickness of nominal 1/2 inch (12.5mm) for studs space 16" on center. OSB shall be installed in accordance with the Applicable Building Code and should be installed in accordance with American Plywood Association recommendations requiring 1/8-inch (3.2 mm) spacing between sheets at ends and sides.
- 3) Exterior Gypsum Sheathing: DensGlass® Gold 8 ft. x 4 ft. x 5/8 in. Exterior Wall Sheathing (or approved equal). Noncombustible as described and tested in accordance with CAN/ULC S114. All panels are to be structural or performance rated sheathing and are to be installed over steel framing members.
- 4) Steel Framing: ClarkDietrich® Cold formed steel framing. Gauge, size and spacing per the design professional. Stud spacing shall not exceed 16" on-center. Horizontal bracing shall not exceed 24" on-center (refer to installation details).
- 5) Weather resistant barriers: Typar® must be placed over the wood or other substrate to protect the materials during construction, provide an air barrier to the building (if required), and to aid in controlling hydration during the curing of the cement plaster base.
- 6) Wire Lath: Structalath® Twin Trac self furring welded wire lath designed to simplify the attachment of wire lath to wood and steel studs. (See installation requirements)
- 7) Accessories: Vinyl Corp® Backer Bead with E-Flange (used on sheathed walls), casing beads, control joints (if specified), and others as specified. E-flange should be used in all cases where attached to Structalath.
- 8) Sealants: Sikaflex 201, Master Seal NP1, or equivalent. One-component, high performance, non-priming, gun-grade, elastomeric polyurethane sealant, requiring no mixing and no priming to bond to concrete or masonry.
- 9) Coating: DRYLOK® Extreme waterproof coating by United Gilsonite Laboratories (UGL), Apply in two coats at a rate of 75 to 100 sf per gallon (≈ 13 - 21 mils **wet** film thickness per coat). Total **dry** film thickness in excess of 12 mils.
- 10) Refer to the Sealed Stucco Isometric on next page for overview

Basic Components Shown. See text, tables and details for specific installation, fastening, coating, sealants, accessories and joint detail requirements.

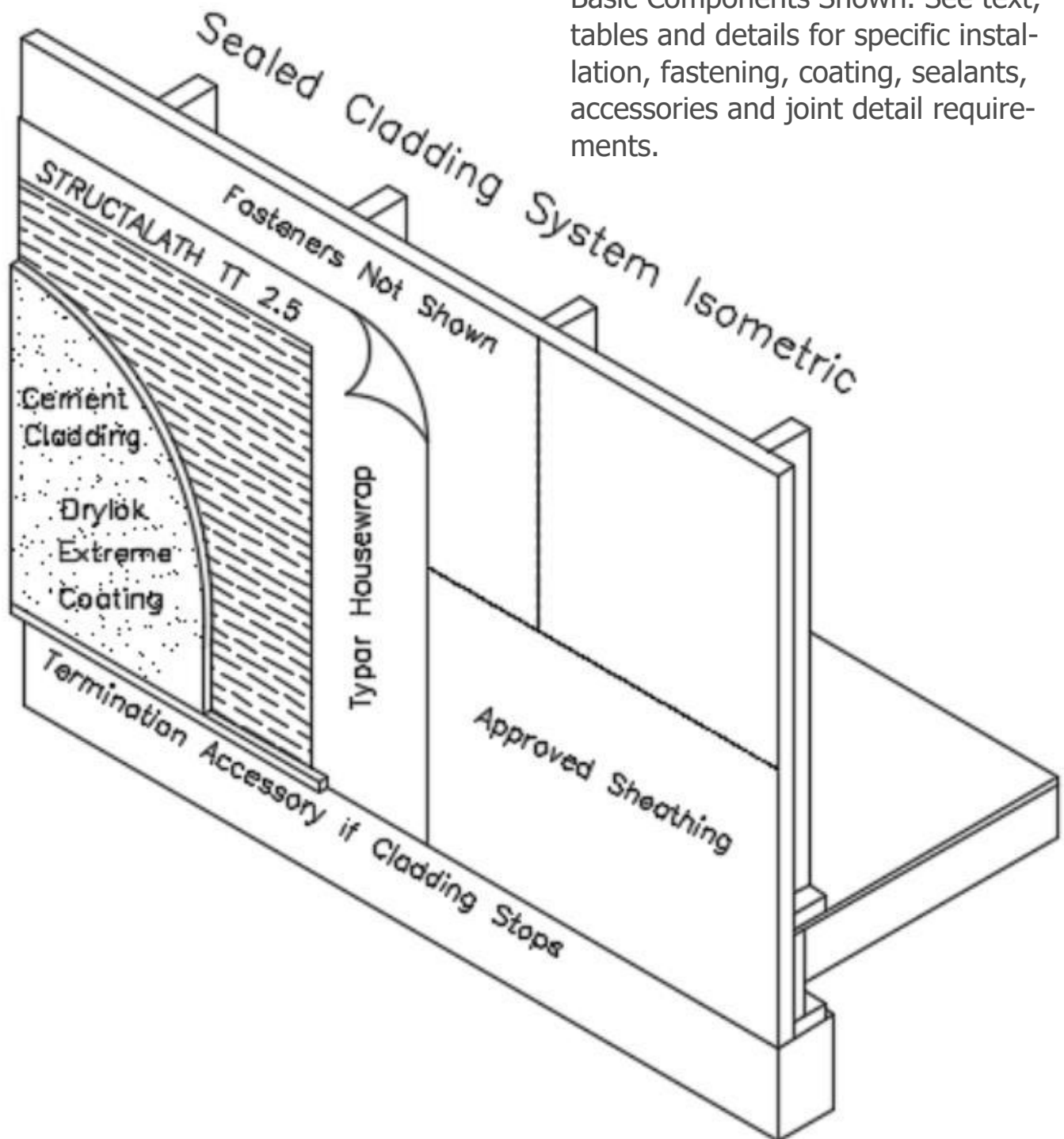

## CHAPTER 03 BUILDING WRAP, LATH AND PLASTER

### Building Wrap:

- 1) Install Typar® Building Wrap over substrate in accordance with the manufacturer's instructions. Refer to [www.typar.com](http://www.typar.com).
  - a. Typar® does not need to be placed over Cement Blocks, Concrete Masonry Units (CMU's), concrete or other solid cementitious materials with suction bases.

### Bonding Agent for Low Suction Bases:

- 2) Drylok Latex Bonding Agent or Lambert Corporation's Acrylbond™ or Lambco 932 Link™ exterior bonding agents may be used if suction is diminished **and** scarifying, scoring or other methods are not viable options. Follow manufacturers instructions. [www.UGL.com](http://www.UGL.com) or [www.lambertusa.net](http://www.lambertusa.net)

### Metal Wire Lath:

- 3) Wire/Metal Lath: Structalath®, manufactured by StructaWire, is the only metal lath/wire approved for installation of the Sealed Cladding System. They both are the same product made by the same manufacturer and either can be used. Structalath shall be installed in accordance with the manufacturer's specifications and required fastening pattern contained in this manual.

### Refer to Safe Attachment Tables for Fastener placement and spacing for Metal Lath.

- 4) Fastening: Wood fasteners shall be a standard #8 x 1" with #2 Phillips head, Zinc-

Plated Steel Truss-Head K-Lath Screws, with a sharp pointed tip.

- a. When staples are permitted (see attachment Table 1) they are to be 16ga Galvanized, Wide Crown Staples; 1" wide x 1" in leg length.
- 5) Screws shall be installed using a standard battery drill operating on the slow setting (approx. 400 rpm) with an adjustable clutch on a setting that will snug the fastener to the Structalath. Note: To ensure proper withdrawal values, do not use impact drivers for fastener installation. The withdrawal value is diminished if the fastener is over-torqued or installed at a high rpm.

### Accessories:

- 5) Corners and Trim Applications: Structalath can be wrapped around outside corners (4 in minimum), or cut into strips and bent to form corner reinforcement strips attached ≈ 12" on center. The corners are then to be rodded during the cement cladding application.
  - a. If corner beads are to be used, they shall be V Truss Straight Corner by Structa Wire. Outside wire corners should be set to be fully embedded in the scratch coat. Final coat will be rodded to cover the wire at least 3/8" for moisture protection.
- 6) Control (*a/k/a* panel) Joints: Although Control Joints are **NOT** required in the Sealed Cladding System, if the plastering or design professional wishes to use them for aesthetics or panelization screeds, they may be installed into the wall assembly in whatever spacing interval desired or specified.

- 5) Normally panel joints are used to break the wall into manageable panels of  $\approx 144$  SF. Panel joints can be applied either vertically or horizontally in the system; although vertical panel joints must be continuous and horizontal panel joints must butt into verticals at intersecting points. Refer to installation details in Chapter 11
- 6) Separate the abutting ends of horizontal and vertical panel joints to  $1/8''$  and fill with sealant. Panel (Control) joints must be installed according to the specifications. See Figures 2a-b.
- 7) Follow Relief Kerf Specifications in Figure 3a and Figure 3b for all casing, penetrations, screeds and separations.
- 8) All other trim, accessories and screeds must be plastic or vinyl materials as manufactured by VinylCorp®.

#### **System Thickness:**

- 11) All accessories are to be set to provide for a total system application thickness of  $\approx 3/4''$  when applied over Structalath and  $\approx 3/8$  in when applied over a solid cement or masonry substrate such as cement masonry units (block) or poured concrete.
- 12) Minimum system thickness over Structalath shall not be less than  $1/2$  inch. Minimum thickness over cement masonry units (block) or poured concrete should not be less than  $1/4$  inch.
- 13) System thickness is measured from the face of the substrate outward to the finished plaster densification coat.

#### **Cement Plaster Application:**

- 14) Mixing and Proportioning: Cement plaster is

to be mixed pursuant to Mixing and Proportioning Section and Mixer Ratios.

#### 15) **Plaster over Structalath®:**

a. Apply a 1st coat ("base" or "scratch" coat) of cement plaster by hand (hawk and trowel) to a depth of  $\approx 3/8$  inch. Scarify with plastering scarifier when the scratch coat plaster has set sufficiently to support the scarifying process.

b. Follow with a 2nd coat ("cover" coat) once the scarified scratch coat has set sufficiently to receive the 2nd coat of cement plaster. Apply with hawk and trowel to a  $3/8$  inch minimum thickness.

c. When hydration (set) has initiated in the cover coat (2nd coat) (finger traces require light pressure), water densify the assembly using an open cell "green" handled float using a circular motion, recharging the plaster with moisture by recharging the float from a water bucket at constant intervals. Float to all grounds and/or screed points.

d. Use a "V" tool to create an angled sealant slot around all penetrations, accessories and terminations. Fenestrations separated using Vinyl Corp's "backer bead" or otherwise separated to use a backer rod do not need a "V" groove. See "V" tooling Section 07 for detailed requirements.

e. Apply finishing decorative dash, spray, texture, final float or stippling to the cladding coat after densification allowing time for the plaster assembly to set sufficiently to accommodate the application of the finishing decoration or applique without moving or deforming the applied plaster. This application process should involve minimum pressure on the green plaster assembly.

**16) Plaster over Cement Masonry Units (block) or Poured Concrete.**

- a. All trim, accessories and screeds must be plastic or vinyl materials as manufactured by VinylCorp®. Although rodding of outside corners may still be preferred by the plaster applicator, Vinyl corner beads are allowed for cement or masonry substrates including associated horizontal wood beams where protected by overhangs or covered porches.
- b. To ensure good bonding ability, higher suction bases such as cement block, porous concrete, etc... should be dampened to inhibit rapid suction losses from the fresh cement plaster.
- c. Drylok Latex Bonding Agent or Lambert Corporation's Acrylbond™ or Lambco 932 Link™ exterior bonding agents may be used if suction is diminished **and** scarifying, scoring or other methods are not viable options or used to aid in controlling hydration (set) time. Follow manufacturers instructions. [www.UGL.com](http://www.UGL.com) or [www.lambertusa.net](http://www.lambertusa.net)
- d. Application should be by hand (hawk and trowel) applying a thin base coat to the substrate with sufficient pressure to ensure a tight bond ( $\approx 1/8$  inch) and rapidly follow with a cover coat of at least  $1/4$  inch pressed onto the fresh bond coat using a hawk and trowel. Minimum system thickness should be  $\approx 3/8$  inch, but should not be less than  $1/4$  inch in thickness.
- e. When hydration (set) has initiated in the cover coat (finger traces require light pressure), densify the assembly using an open cell "green" handled float using a circular motion, recharging the plaster with moisture by recharging the float from a water bucket

at constant intervals. Float to all grounds and/or screed points.

- f. Use a "V" tool to create an angled sealant slot around all penetrations and terminations. Fenestrations separated using Vinyl Corp's "backer bead" or otherwise separated to use a backer rod do not need a "V" groove. See "V" tooling Section 07 for detailed requirements.
- g. Decorative finish dash, spray, texture, final floating or stippling decoration or applique may be immediately applied to the cement plaster cover coat.

**For all Plaster Applications:**

- 17) Application of any cement plaster or plaster coats using slickers, darbys, rods or application boards of any kind is not permitted.
  - a. A darby or rod may be used to straighten the surface to relieve the face application of minor voids or irregularities by leveling with small amounts of fresh plaster to "fill-in" cavities or blemishes during the finishing process.

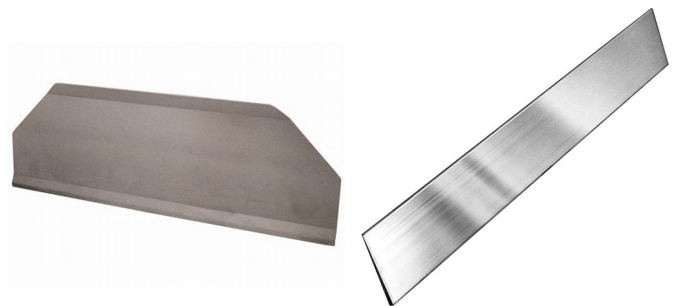
**Not for Applying Base or Cover Coats - Straightening Finish Coat Only**



## CHAPTER 04 DETERMINING WALL PRESSURES

- 1) Walls are subject to positive and negative pressures during wind events. Air moving across a building is affected by the building's geometry, therefore, building edges, corners and roof planes cause the wind to redirect itself around these obstacles creating aerodynamic forces that vary depending upon location.
- 2) Just like air passing over an airfoil (wing of an airplane), the air travels a longer distance over the top of the wing creating a negative pressure or "lift". It is this same process that causes formidable loads on the exterior of a building's roof and walls, creating zones of pressures on the building's geometry.
- 3) Wall Zone pressures are labeled 4 and 5, respectively, with Zone 5 representing a 4 foot horizontal distance in both directions from any outside corner on any residential con-

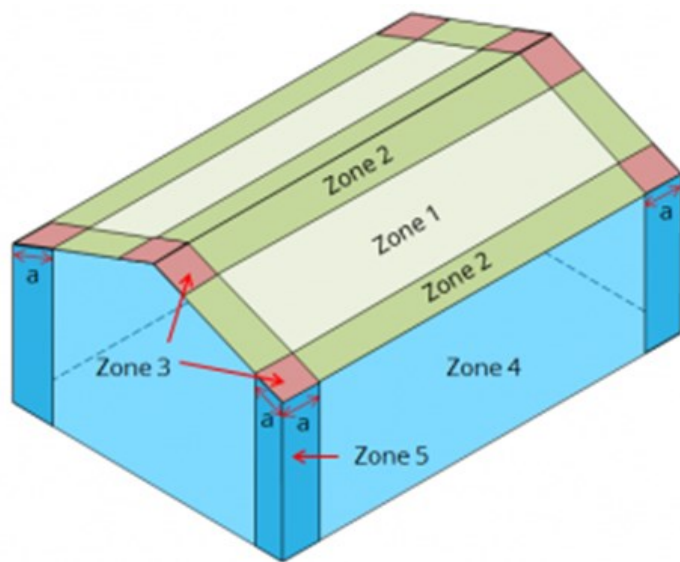

Figure 4-1 Pressure Zones for Walls

struction (called distance "a"). On Commercial Buildings, this distance is uniquely calculated using a formula. (Refer to Figure 4-1). These pressures (loads) must be determined and dealt with by the plasterer.

- 4) Although the wall pressures are different within Zone 4 and Zone 5, the greatest suction loads will be located within Zone 5. Therefore we will design our entire metal wire / lath attachment based upon the expected force in pressure Zone 5.
- 5) Loads imposed upon cement plaster systems applied to a direct suction base such as concrete or concrete masonry units (cement blocks) are not a concern to the plasterer since the uniform suction of the cement to the solid mass of the substrate provides the rigidity necessary to resist these forces.
- 6) Loads imposed upon cement plaster applied over metal wire / lath is an entirely different matter. Even where metal lath is placed over solid structural sheathing, where the sheathing resists the positive pressure of the wind-stream, it does not provide resistance to the negative (suction) forces.
- 7) This suction load pulls directly upon both the fasteners (withdrawal) and the plaster assembly (convex) through the metal wire / lath attachment spacing. The fasteners must resist both of these applied loads. If the fasteners fail in withdrawal, the system fails - if the fasteners hold in withdrawal but their spacing pattern is too large, the system will "bow" or "bend" (convex) in between their spacings - creating an outward deflection causing the system to rupture (fracture) and fail. Successful system attachment is dependent upon factoring both of these two separate anchorage aspects.

8) Therefore, successful performance of any cladding system is dependent upon the fastener's anchorage ability for withdrawal and the requisite fastening pattern ascribed to resist convex deformation of the cement plaster assembly under the building's specific wind loading conditions.

### Safe Attachment Tables:

9) In order to ensure safe attachment for cladding systems, the following Safe Attachment Tables and their associated Fastening Placement Tables have been prepared according to testing results derived from ASTM 330 testing data as required (and prescribed) by the ICC and Florida Building Codes. The full publication with all supporting testing data and reports can be downloaded at the Stucco Institute; titled "Safe Attachment Tables for Metal Lath".

10) Each Table represents a specifically prepared full wall specimen that was assembled and tested in an accredited testing facility in accordance with ASTM 330.

11) The testing criteria require all loads to be proofed at a factor of safety of 1-1/2 times the published rating. The published data in this manual tabulates attachment requirements for varying pressures and three factors of safety; 1.5; 2.5; and 3. A factor of no less than 2.5 should be used for claddings and a factor of 3 is most commonly used. Refer to Fastening Tables for application of code prescribed safety factors (FoS) in Chapter 05 of this manual.

12) One cannot use the Safe Attachment Tables until the wall pressures have been determined by themselves or others. If you have the wall pressures in pounds per

square foot (psf) then you may pass to the Safe Attachment Tables at Chapter 05.

### Determining the Wall Pressure:

13) Determining the wall pressures (in pounds per square foot) is a code requirement and necessary to ensure proper cladding performance by ensuring proper attachment.

14) The design professional of record should place the wall and roof design pressures on the approved plan. This is usually mandatory on new commercial plans and is frequently required on new residential plans.

15) If, however, the pressures are unknown and / or unpublished - then the plasterer will need to obtain or determine it. The calculations are based upon the ASCE 7 - 10. This document is quite formidable for those who haven't been schooled in its methodology. So, there are several internet sites that will calculate these pressures fairly easily, such as: <https://www.engineeringexpress.com/calculators19/> or [skyciv.com](http://skyciv.com)

16) Most of these are free to use with printed results and most will provide an engineered sealed submission sheet for a fee.

17) If you are working on a residential home, the residential code makes the process quite simple; it's a several step process.

18) Our Design Example: Three story residential home with metal wire / lath attached to structural wood panels. It will have a face barrier (exterior painted) cement cladding system. **Located in Tampa Florida, on Tampa Bay; fairly flat terrain; with an average roof height of 35 feet. Using the 2017 Florida (or ICC) Residential Code:**

**Step 1**

**Determine the Wind Speed From FIGURE R301.2(4) - ULTIMATE DESIGN WIND SPEEDS Vult.**

Think of the meaning of Vult as “Ultimate Velocity of the wind”. The red arrow points to the position of the residence. Read the windspeed isotach lines from the higher towards the lower, consider anything within the 150 at the 150 speed until the 140 line is reached. Anything within the 140 is considered 140 until the 130

line is reached, etc. Although engineers may interpolate between the lines, it is wise just to use the higher value since the slight difference interpolation provides is of little consequence to the cement cladding pressures,

So, Our Wind Speed = **150 mph**

**Step 2**

**Determine the Ground Surface Terrain and Exposure Classification**

*R301.2.1.4.2 Surface roughness categories. A ground surface roughness within each 45-degree (0.79 rad) sector shall be determined for a distance upwind of the site as defined in Section R301.2.1.4.3 from the categories defined below, for the purpose of assigning an exposure category as defined in Section R301.2.1.4.3.*

**Surface Roughness B.** Urban and suburban areas, wooded areas or other terrain with numerous closely spaced obstructions having the size of single-family dwellings or larger.

**Surface Roughness C.** Open terrain with scattered obstructions having heights generally less than 30 feet (9144 mm). This category includes flat open country and grasslands. This Surface Roughness shall also apply to any building located within Surface Roughness B-type terrain where the building is within 100 feet (30.5 m) horizontally in any direction of open areas of Surface Roughness C- or D-type terrain that extends more than 600 feet (182.9 m) and width greater than 150 feet (45.7 m) in the upwind direction.

**Surface Roughness D.** Flat, unobstructed areas and water surfaces. This category includes smooth mud flats, salt flats and unbroken ice.

So, our Surface Roughness = **D** (open water)

**FIGURE R301.2(4)**

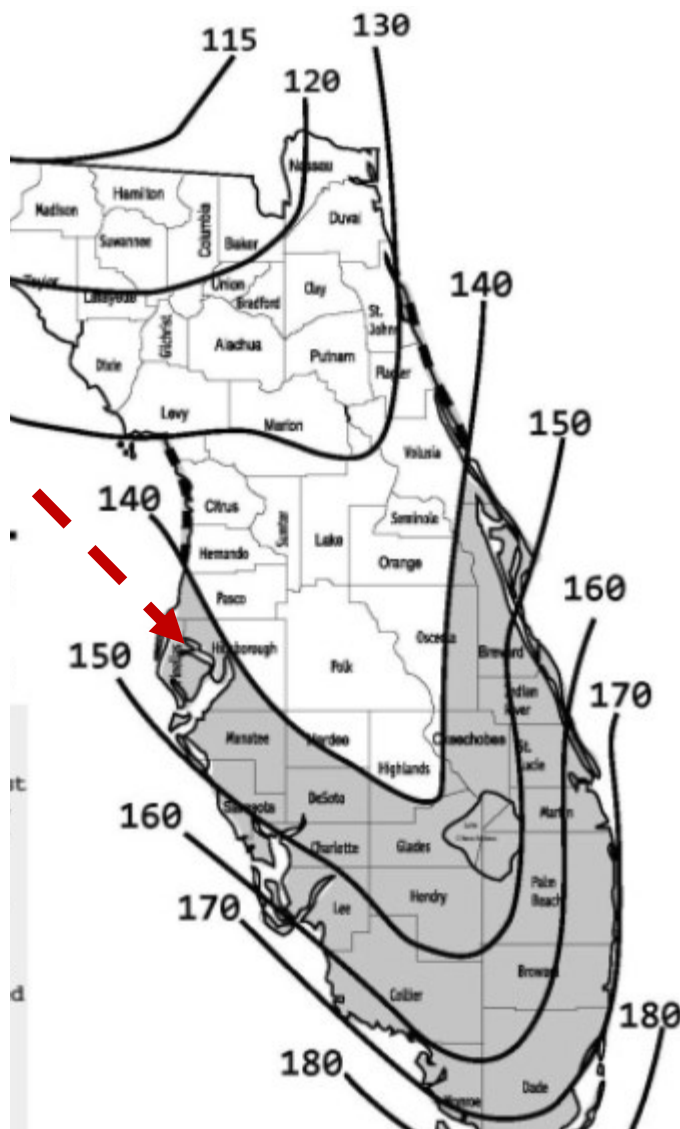

Next check to see if the Exposure Category "for the Ground Surface Roughness remains "D" or is reclassified based upon the criteria for Exposure Categories at:

### **R301.2.1.4.3 Exposure categories.**

An exposure category shall be determined in accordance with the following:

**Exposure B.** For buildings with a mean roof height of less than or equal to 30 feet (9144 mm), Exposure B shall apply where the ground surface roughness, as defined by Surface Roughness B, prevails in the upwind direction for a distance of at least 1,500 feet (457 m). For buildings with a mean roof height greater than 30 feet (9144 mm), Exposure B shall apply where Surface Roughness B prevails in the upwind direction for a distance of at least 2,600 feet (792 m) or 20 times the height of the building, whichever is greater.

**Exposure C.** Exposure C shall apply for all cases where Exposures B or D do not apply.

**Exposure D.** Exposure D shall apply where the ground surface roughness, as defined by Surface Roughness D, prevails in the upwind direction for a distance of at least 5,000 feet (1524 m) or 20 times the height of the building, whichever is greater. Exposure D shall also apply where the ground surface roughness immediately upwind of the site is B or C, and the site is within a distance of 600 feet (183 m) or 20 times the building height, whichever is greater, from an Exposure D condition as defined in the previous sentence.

So, our Exposure Category Remains = **D**  
(Tampa Bay is wider than 20 times the height of the building)

### **R301.2.1.5.1 Simplified topographic wind speedup method.**

Structures located on the top half of isolated hills, ridges or escarpments are subject to wind speed-up effects. Although there is a simplified Table for a wind speed increase accounting for these effects, **a licensed design professional should be consulted** for determining the velocity increases and tabulation of the final pressures on hills or escarpments. See Figure 4-02

**So far our Wind Speed is 150 mph and our Surface Roughness and Exposure Category is Exposure "D" and our mean roof height is 35 feet**

Now we go to TABLE R301.2(2) to determine the wall design pressure of our residence using the data above. Refer to the Table on the following page:

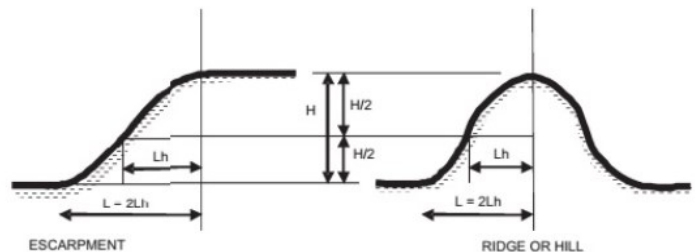

Figure 4-02 - Locations within Escarpments or Location on Ridges and Hills. Use an engineer to calculate wind pressures where building is sited in this condition

**Step 3 - Determine the Component and Cladding Loads (Pressures +/-)**

The table (modified to fit for our example) lists the actual wall pressure based upon the windspeed we determined in Step 1 (150 mph). We have already discussed the fact that wall pressure Zones are divided into either Zone 4 or Zone 5. We will use Zone 5 pressure (since it represents the worst-case condition) to design the attachment and spacing of our cladding system’s metal wire/lath.

Note that all Zones have effective wind area ranges from 10 to 500 ft.<sup>2</sup>. We will always use the effective wind area of 10 ft.<sup>2</sup> for the design of claddings (it’s a requirement specifically listed in another section of the code). Therefore we simply enter the table at the far left-hand column under Zone, running our finger down until we intersect Zone 5 adjacent to the effective wind area of 10 ft.<sup>2</sup>. We then slide horizontally to the right until we intersect the two numbers under the windspeed of 150 mph. We have drawn a box around the two numbers which are 24.3 and -32. The first number is the positive pressure, the second number is the negative pressure. We simply use the worst-case load which is 32 pounds per square foot negative.

The Table’s Heading explains that these tabulated pressures are based upon a mean (average) roof height of 30 feet and a residence located in Exposure category "B". If any of these two variables are different than the house you are designing the cladding system for (and our example is different in both respects) you need to adjust one, or the other, or both, as we will do next.

**So far our design pressure is -32 psf based upon a 30 feet mean roof height and an Exposure Category of "B" - But our house is Exposure "D" and our mean roof height is 35 feet. So, let’s adjust our pressure**

**TABLE R301.2(2)  
COMPONENT AND CLADDING LOADS FOR A BUILDING WITH A MEAN ROOF HEIGHT OF 30 FEET LOCATED IN EXPOSURE B (psf)**

WALL	ZONE	EFFECTIVE WIND AREA (feet <sup>2</sup> )	ULTIMATE DESIGN WIND SPEED, $V_{ULT}$ (mph)												
			110		115		120		130		140		150		
	4	10	13.1	-14.0	14.3	-15.0	15.5	-16.0	18.2	-19.0	21.2	-22.0	24.3	-26.0	27
	4	20	12.5	-13.0	13.6	-14.0	14.8	-16.0	17.4	-19.0	20.2	-22.0	23.2	-25.0	26
	4	50	11.7	-12.0	12.8	-14.0	13.9	-15.0	16.3	-17.0	19.0	-20.0	21.7	-23.0	24
	4	100	11.1	-12.0	12.1	-13.0	13.2	-14.0	15.5	-17.0	18.0	-19.0	20.6	-22.0	23
	4	500	10.0	-10.0	10.6	-11.0	11.6	-12.0	13.6	-15.0	15.8	-17.0	18.1	-20.0	20
	5	10	10.0	-17.0	14.3	-19.0	15.5	-20.0	18.2	-24.0	21.2	-28.0	24.3	-32.0	27
	5	20	12.5	-16.0	13.6	-17.0	14.8	-19.0	17.4	-22.0	20.2	-26.0	23.2	-30.0	26
	5	50	11.7	-14.0	12.8	-16.0	13.9	-17.0	16.3	-20.0	19.0	-23.0	21.7	-27.0	24
	5	100	11.1	-13.0	12.1	-14.0	13.2	-16.0	15.5	-19.0	18.0	-22.0	20.6	-25.0	23
	5	500	10.0	-10.0	10.6	-11.0	11.6	-12.0	13.6	-15.0	15.8	-17.0	18.1	-20.0	20



**Step 4**  
**Adjust for Mean Roof Height and Exposure Category if Necessary at Table R301.2(3)**

Since our House has a Mean Roof Height of 35 feet and is located within Exposure Category "D", the adjustment factor is 1.70

So,  $32 \times 1.70 = 54.4$  or **55 PSF** actual load

We will use this pressure to move forward and determine the correct attachment for our metal wire / lath.

The safe attachment tables that follow are used to determine the fastener type and pattern for the loads that have been determined in Step 4.

Remember, the loads were calculated based upon the pressures exerted in Zone 5 (which represent the maximum wall wind loading condition).

Technically, the fastening pattern could be calculated for Zone 4 (interior residential wall sections starting greater than 4 feet from any corner) and might allow for two different fastening patterns; 1 pattern for Zone 4 and a another more aggressive pattern for Zone 5.

Considering that the fasteners saved represent a negligible cost - and the fact that installers would need to understand and use two distinct patterns in two distinct area around the buildings perimeter - this is simply is more trouble than it is worth.

Therefore always calculate the pressures in Zone 5, establish the correct fastener and fastening pattern from the following "safe attachment tables" and attach all metal/wire lath using the same pattern - regardless of the Zone location.

So, let's find a fastener and fastening pattern for :

**55 psf:**

**TABLE R301.2(3)**  
**HEIGHT AND EXPOSURE ADJUSTMENT**  
**COEFFICIENTS FOR TABLE R301.2(2)**

MEAN ROOF HEIGHT	EXPOSURE		
	B	C	D
15	1.00	1.21	1.47
20	1.00	1.29	1.55
25	1.00	1.35	1.61
30	1.00	1.40	1.66
35	1.05	1.45	1.70
40	1.09	1.49	1.74
45	1.12	1.53	1.78
50	1.16	1.56	1.81
55	1.19	1.59	1.84
60	1.22	1.62	1.87

## CHAPTER 05 FASTENER REQUIREMENTS AND PATTERNS

### Safe Attachment Tables:

- 1) The following Safe Attachment Tables and their associated Fastening Placement Tables have been prepared according to testing results derived from ASTM 330 testing data as required (and prescribed) by the ICC and Florida Building Codes.
- 2) Each Table represents a specifically prepared full wall specimen that was constructed and tested in an accredited testing facility.
- 3) The ASTM 330 states that all loads must be proofed to 1-1/2 times the published rating. This factor takes into account the variables of ideal assemblage in a controlled testing environment that rarely happen in real world installations (Refer to Fastening Tables for application of code prescribed Factors of Safety (FoS).
- 4) The code generally requires a FoS of 2.5 for claddings as a minimum while design professionals frequently use a FoS of 3.
- 5) The following tables are tabulated using a Factor of Safety of 1.5, 2.5 and

3 respectively.

- 6) Tables Start on Next Page. Using a Factor of Safety (FoS) of 2.5 as a minimum, with our example design, we will need a fastener and fastening pattern to resist **55** psf - So use Table **T-4** (Which Yields 67.5 psf) and note that the lath **MUST** be attached using the Fastener **Pattern** shown in Table **F-4**.
- 7) This will require screws placed in vertical rows 6" oc and 12" oc horizontal using a STAGGERED pattern. See Table F-4. *Installation note; staples can be used to initially hang wire lath if desired but do not count as attachment fasteners.*

*Note 1; This publication has been modified to only show data relevant to the Sealed Cladding System. For the complete article and testing reports go to [stuccoinstitute.com](http://stuccoinstitute.com) and print the article: "Safe Attachment Tables For Metal Lath to Plywood, OSB and other Structural Panels for Code Compliance"*

*Note 2; Tables can be used for standard 2.5 expanded metal lath. Simultaneous control tests were performed with similar results. Their testing data was not posted in this manual since the StructaLath twin trac wire lath is the only approved mechanical keying (lath) material allowed for the Sealed Cladding System.*





**SAFE ATTACHMENT TABLE T-1**  
**See Fastener Placement Table F-1**

**STAPLE ATTACHMENT INTO 16" O.C. VERTICAL WOOD FRAMING MEMBERS  
AT 7" MAXIMUM VERTICAL INTERVALS (OR STEEL<sup>1</sup>) FRAMING MEMBERS WITH SCREW ATTACHMENT**

**ASTM 330 TEST METHODOLOGY RESULTS**

**2.5 Expanded Metal Lath Installed over Wood Studs Spaced 16" on center. Lath Attached with Staple or Screw<sup>1</sup> Fasteners Vertically Spaced 7" on center**

**Attachment according to the ASTM C-1063**

Attachment Data and Spacing	Listed Load Proofed for FoS of 1.5 per ASTM 330 Test Requirement	Allowable Load in psf Using Code Applied Load FoS of 2.5 per 1709.3	Allowable Load in psf Using Code Applied Load FoS of 3.0 per ASCE 7	Tributary Area in2 / Fasteners p/s/f
16 ga. 1" crown x 1" leg galvanized staples spaced 7" on center into vertical framing members spaced 16" horizontally on center	50	30	25	112 / 1.28

ASTM E 330: *Standard Test Method for Structural Performance of Exterior Windows - FoS = Factor of Safety - Allowable Loads are obtained by multiplying the laboratory published proofed load by 1.5 and dividing by FoS - Designers often require a FoS of 3 for claddings and may be required when designing buildings of higher importance as defined in ASCE 7*

*Author Note : Most ASTM installations are installed wholly or partially over open framing as tested in this specimen. Although there was no sheathing installed over the studs the results would have been the same since failure was in the negative direction. In other words , even if sheathing were to have been used, if the nails were placed in the same vertical stud lines, the effects would be the same since failing force was initiated on the negative pressure cycle.*

<sup>1</sup> *A 16" o.c. steel stud frame assembly was covered with 5/8" DensGlass sheathing. #8 x 1-1/4" Lath screws were used to attach the Metal Lath to the studs 6" o.c. vertically. 1 - "C" track was place horizontally at the 4' (midwall) point with screws attaching the lath to the midwall strap (track) 6" horizontally o.c. The wall failed to proof at a higher value than those listed above. See Table T-5 for Steel Framing configurations requiring higher values.*

### Fastening Placement Table F-2

See Table T-2 for Fasteners Specifications and Allowable Load

- Wall Covered with 1/2" Nominal Structural Panel Sheathing
- Staples or Nails Placed 6" O.C. Each Way - Fasteners Offset Every Other Row

Drawing NTS - Illustrative only

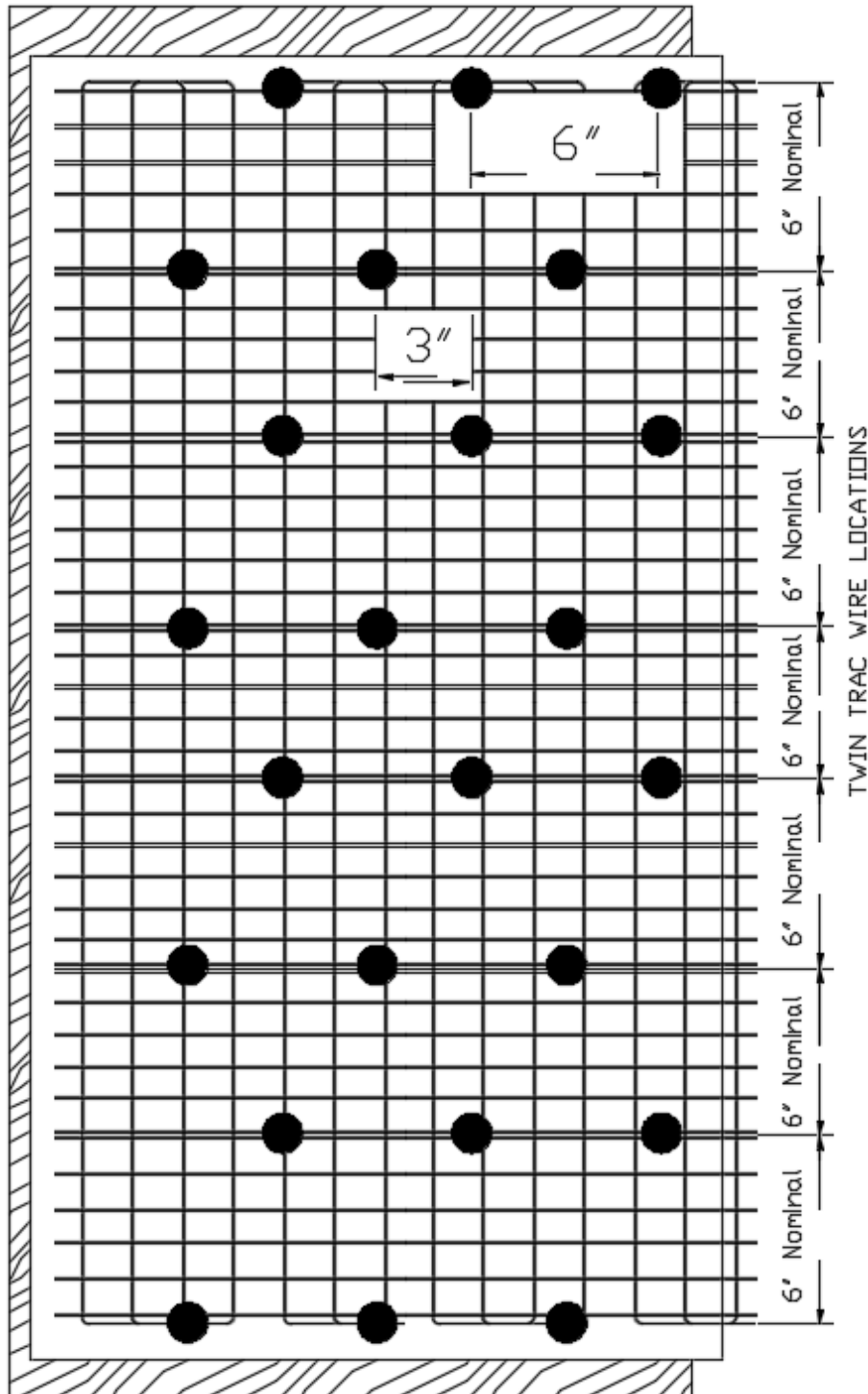

**SAFE ATTACHMENT TABLE T-2**  
**REFER TO Fastener Placement Table F-2**

**STAPLE ATTACHMENT TO STRUCTURAL WOOD PANELS ≈ 6" O.C. EACH WAY**

**ASTM 330 TEST METHODOLOGY RESULTS**

**StructaLath No. 17 SFRC Twin Trac 2.5 installed over 1/2 nominal (7/16 minimum) structural panel sheathing attached to studs or sub-framing per design using 1" leg x 1" crown, 16ga. galvanized steel staples spaced maximum 6" o.c. along the horizontal dimension on the twin track. The rows were spaced vertically a maximum 6" o.c. and offset 3" o.c. from the preceding row.**

Attachment Data and Spacing	Listed Load Proofed for FoS of 1.5 per ASTM 330 Test Requirement	Allowable Load in psf Using Code Applied Load FoS of 2.5 per 1709.3	Allowable Load in psf Using Code Applied Load FoS of 3.0 per ASCE 7	Tributary Area in <sup>2</sup> / Fasteners p/s/f
16 ga. 1" crown x 1" leg galvanized staples spaced 6" vertically into structural wood sheathing panel and fastener spacing of 6" horizontally on center with each row placement offset 3" to achieve a staggered pattern	60	36	30	36 / 4

*ASTM E 330: Standard Test Method for Structural Performance of Exterior Windows - FoS = Factor of Safety - o.c. = on center - Allowable Loads are obtained by multiplying the laboratory published proofed load by 1.5 and dividing by FoS - Designers often require a FoS of 3 for claddings and may be required when designing buildings of higher importance as defined in ASCE 7.*

### Fastening Placement Table F-3

See Table T-3 for Fasteners Specifications and Allowable Load

- Wall Covered with 1/2" Nominal Structural Panel Sheathing
- Screws Placed 16" O.C. Each Way - Fasteners Offset 8" Every Other Row

Drawing NTS - Illustrative only

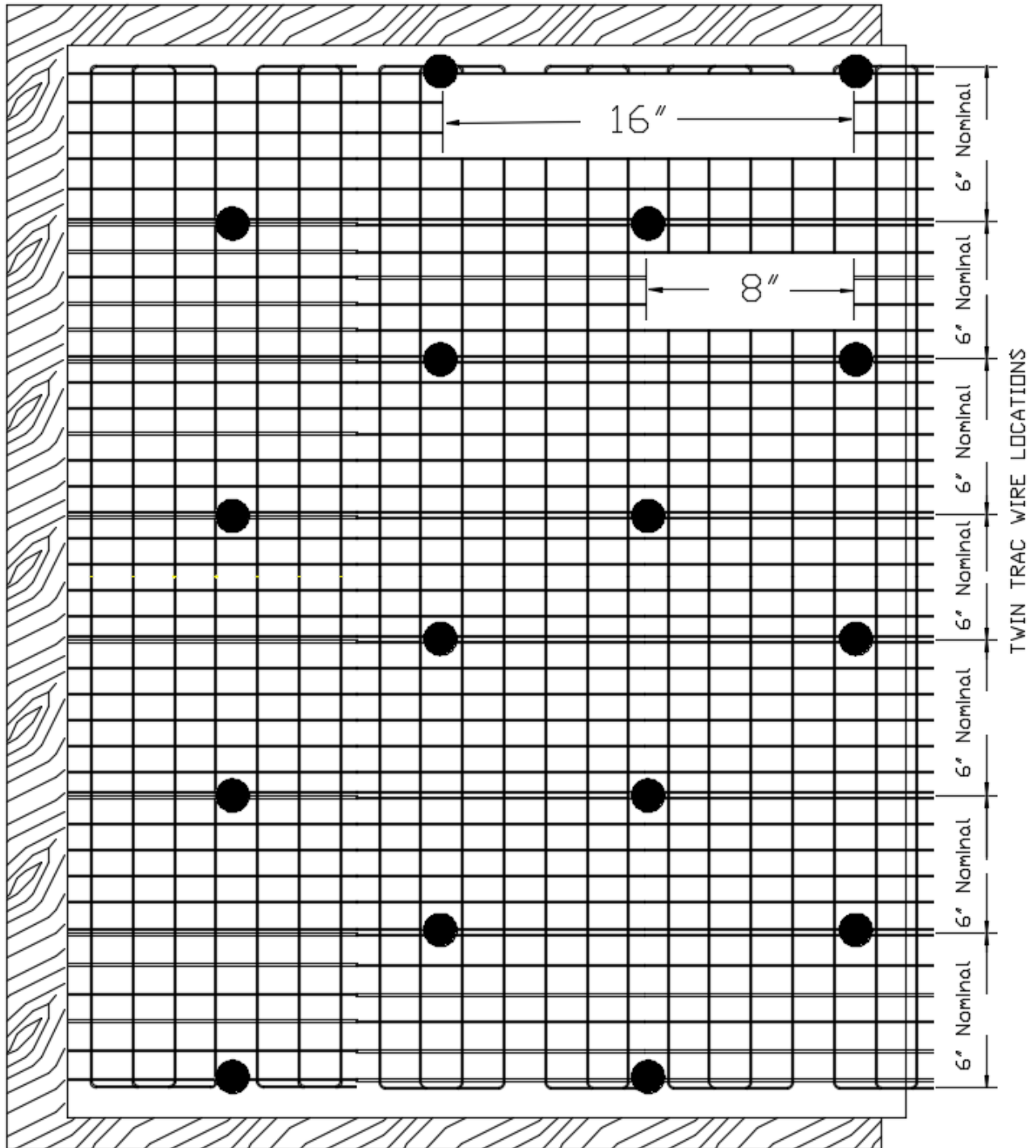

**SAFE ATTACHMENT TABLE T-3**  
**REFER TO Fastener Placement Table F-3**

**SCREW ATTACHMENT TO STRUCTURAL WOOD PANELS ≈ 6" VERTICAL AND 16" HORIZONTAL**

**ASTM 330 TEST METHODOLOGY RESULTS**

**StructaLath No. 17 SFRC Twin Trac installed with screws spaced maximum 16" o.c. along the horizontal dimension. Attachment rows spaced vertically 6" o.c. and offset 8" o.c. from the preceding row.**

Attachment Data and Spacing	Listed Load Proofed for FoS of 1.5 per ASTM 330 Test Requirement	Allowable Load in psf Using Code Applied Load FoS of 2.5 per 1709.3	Allowable Load in psf Using Code Applied Load FoS of 3.0 per ASCE 7	Tributary Area In2 / Fasteners p/s/f
StructaLath No. 17 SFRC Twin Trac 2.5 was installed with #8 x 1" truss-head, K-lath screws spaced maximum 16" o.c. along the horizontal dimension on the twin track. The attachment rows were spaced vertically a maximum 6" o.c. and offset 8" o.c. from the preceding row.	75	45	37.5	96 / 1.5

*ASTM E 330: Standard Test Method for Structural Performance of Exterior Windows - FoS = Factor of Safety - o.c. = on center - Allowable Loads are obtained by multiplying the laboratory published proofed load by 1.5 and dividing by FoS - Designers often require a FoS of 3 for claddings and may be required when designing buildings of higher importance as defined in ASCE 7*

### Fastening Placement Table F-4

See Table T-4 for Fasteners Specifications and Allowable Load

- Wall Covered with 1/2" Nominal Structural Panel Sheathing
- Screws Placed 12" O.C. Each Way - Fasteners Offset 6" Every Other Row Pattern

Drawing NTS - Illustrative only

Note; This pattern has been the South Florida Building Code requirement for many decades

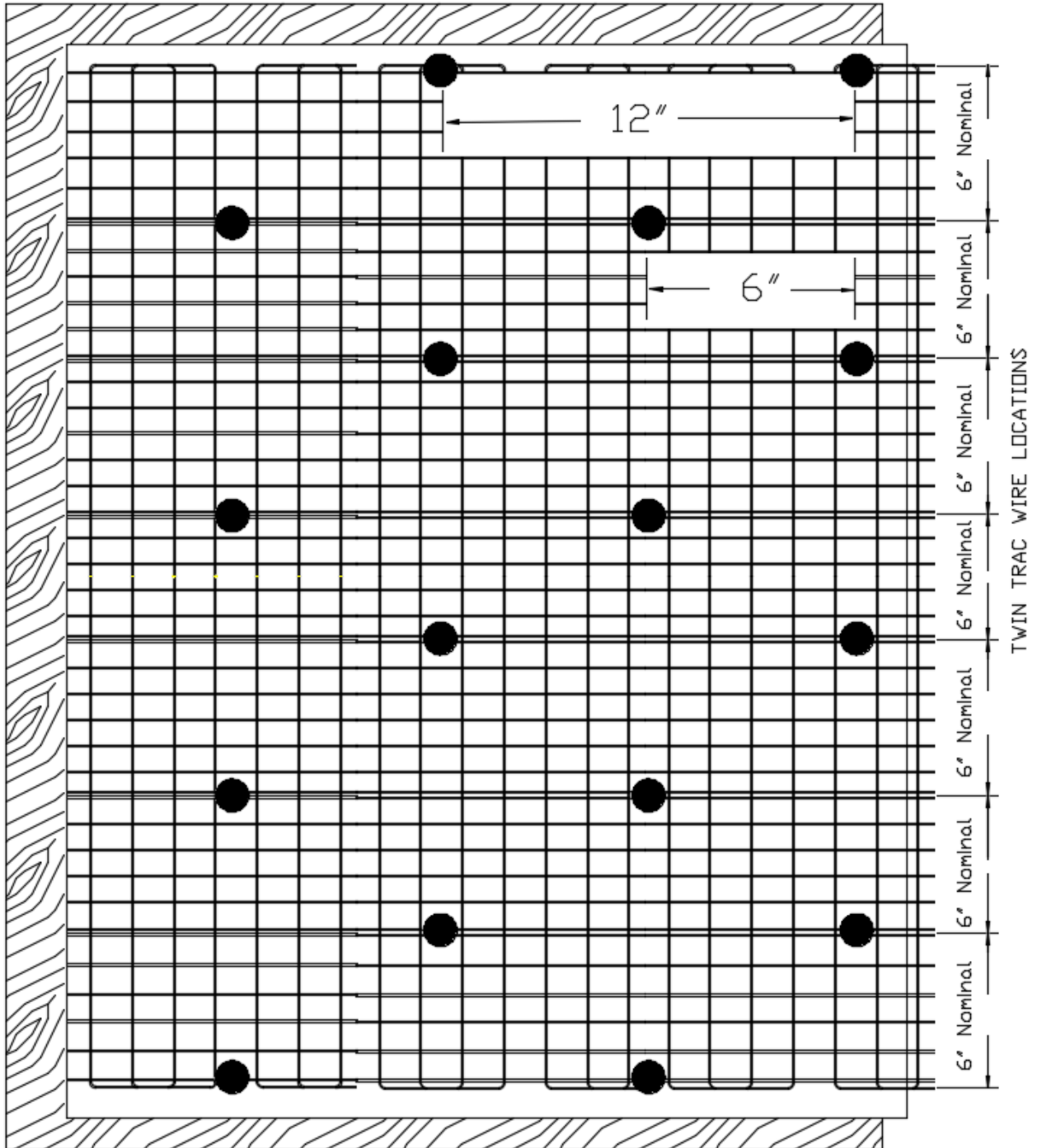

**SAFE ATTACHMENT TABLE T-4**  
**REFER TO Fastener Placement Table F-4**

**SCREW ATTACHMENT TO STRUCTURAL WOOD PANELS ≈ 6" VERTICAL AND 12" HORIZONTAL**

**ASTM 330 TEST METHODOLOGY RESULTS**

**StructaLath No. 17 SFRC Twin Trac installed with screws spaced maximum 12" o.c. along the horizontal dimension. Attachment rows spaced vertically 6" o.c. and offset 6" o.c. from the preceding row.**

Attachment Data and Spacing	Listed Load Proved for FoS of 1.5 per ASTM 330 Test Requirement	Allowable Load in psf Using Code Applied Load FoS of 2.5 per 1709.3	Allowable Load in psf Using Code Applied Load FoS of 3.0 per ASCE 7	Tributary Area In2 / Fasteners p/s/f
StructaLath No. 17 SFRC Twin Trac 2.5 was installed with #8 x 1" truss-head, K-lath screws spaced maximum 12" o.c. along the horizontal dimension on the twin track. The attachment rows were spaced vertically a maximum 6" o.c. and offset 6" o.c. from the preceding row.	112.5	<div style="text-align: center;"> <span style="border: 2px solid red; border-radius: 50%; padding: 5px;">67.5</span>                      Should meet most any design attachment requirement                 </div>	56.25	72      2  South Florida Code

*ASTM E 330: Standard Test Method for Structural Performance of Exterior Windows - FoS = Factor of Safety - o.c. = on center - Allowable Loads are obtained by multiplying the laboratory published proofed load by 1.5 and dividing by FoS - Designers often require a FoS of 3 for claddings and may be required when designing buildings of higher importance as defined in ASCE 7*

*The requirement for 2 fasteners p/s/f was a South Florida Building Code requirement for over 50 years. Unknowledgeable professionals lobbied for consolidation of text and it was eliminated by the Florida Code Commission in the 2010 Florida Building Code. That has proven to be a serious unintended error in Florida.*



### Fastening Placement Table F-5

See Table T-5 for Fasteners Specifications and Allowable Load

- Studs Covered with 1/2" Nominal Thickness Exterior Gypsum Panel Sheathing (DensGlass)
- Screws Placed 6" O.C. At Vertical Studs Spaced 16" o.c. and 4" o.c. at Horizontal Framing Spaced 2' o.c.

Drawing NTS - Illustrative only

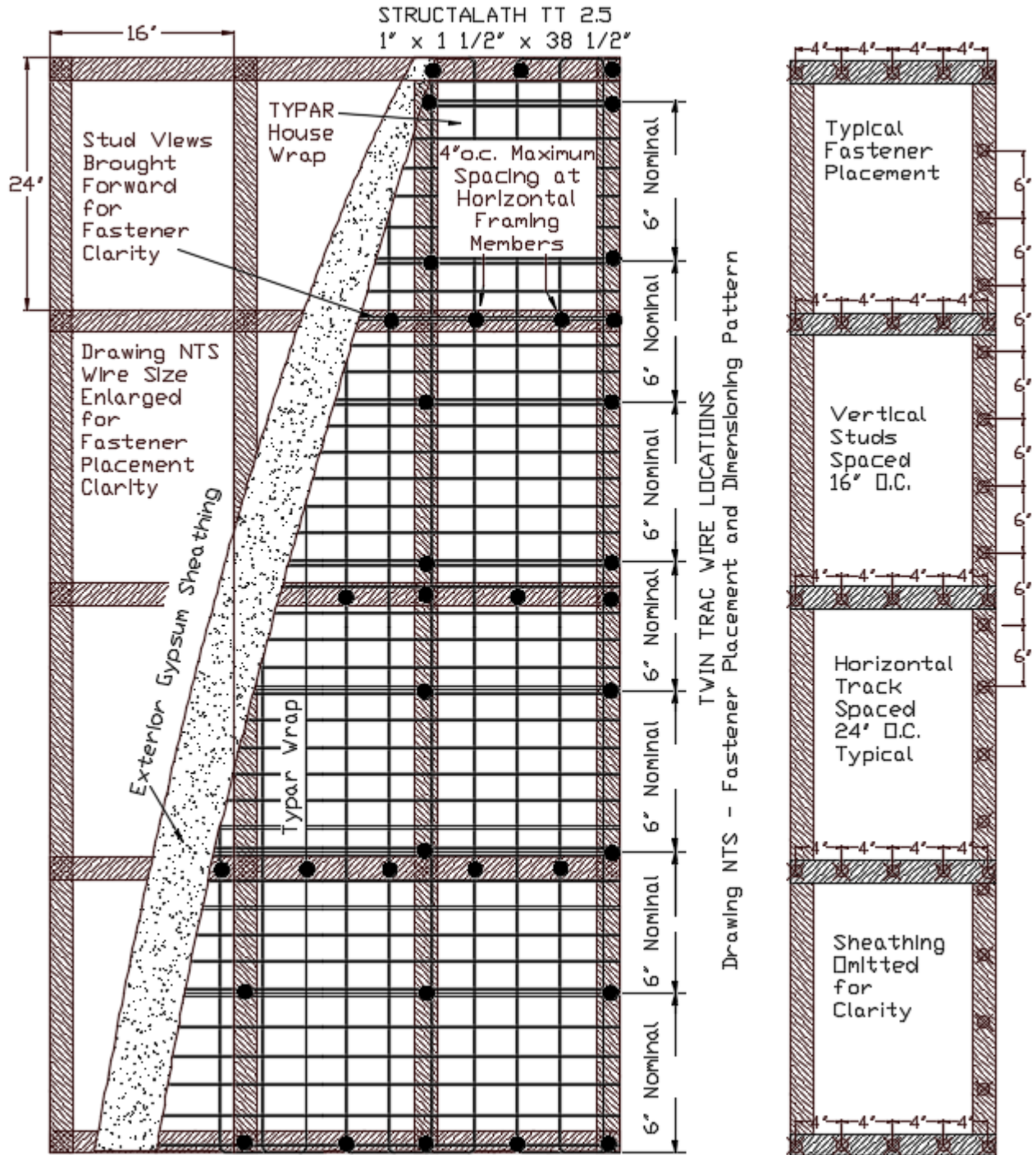





## CHAPTER 06

### MIXING AND PROPORTIONS

#### Mixing Ingredients and Ratios:

##### 1) Sand:

Sand must be clean and free of all organic or foreign matter. Sand gradation shall be standard "sharp" graded cement plastering sand with a maximum particle size of 3/16 inch, but with a greater proportion of large particles, and less very fine sand. Comply with BS EN 13139:2013 Aggregates for mortar.

##### 2) Mix Ratios:

Cement Plaster Mix for Cladding Application:

- a. 1 bag ( $\approx$  80 lbs. or 1 cubic foot) Type "S" cement mortar mixed with 4 to 5 cubic feet of cement plaster sand yielding a 1:4 to 1:5 ratio using potable water.
- or -
- 1 bag Portland Cement ( $\approx$  94 lbs. or 1 cubic foot) and 1/2 bag hydrated lime ( $\approx$  25 lbs. or 1/2 cubic foot) or other approved plasticizer mixed with 4 to 5 cubic feet of cement plaster sand yielding a 1:4 to 1:5 ratio using potable water.

##### 3) Volume Measurements:

Shovel:

#2 Round point  $\approx$  7 shovels per cubic foot.  
#2 Square point  $\approx$  4-1/2 shovels per cubic foot.

Bucket:

5 Gallon Bucket  $\approx$  5/8 Cubic Foot. Therefore (3) Three 5 Gallon Buckets  $\approx$  2 Cubic Feet

#### Counting shovels is not recommended because of unreliability.

- 4) Determining the mixer size and using its quantity to develop the mix ratios as described in the following paragraphs is the preferred method.

Mixer size can be found by contacting the manufacturer with the Model Number, but usually simply deduced from the first letter in Model Number itself; Model 655 = 6 CF or WM70 = 7 CF. If the name or plate is not available, use formula 4.1 for manual calculation.

#### Mixer Ratios:

##### For a typical 4 cubic foot mixer:

Place  $\approx$  2 -1/2 gallons of water and 4 shovels of sand to the running mixer. Add 1 bag of Type "S" Mortar, Listen to mixer, add water if straining. Fill mixer full with sand and additional water as needed. Ratio = 1:4

##### For a typical 6 cubic foot mixer:

Place  $\approx$  3-1/2 gallons of water and 7 shovels of sand to the running mixer. Add 1-1/2 bags of Type "S" Mortar mix or 1 bag Portland cement and 1/2 bag (1/2 cubic foot) of lime or other plasticizer as directed by manufacturer. Listen to mixer, add water if straining. Fill mixer by adding sand and additional water as needed. Ratio = 1:4

##### For a typical 7 cubic foot mixer: (best size)

Place  $\approx$  4 gallons of water and 8 shovels of sand to the running mixer. Add 1-1/2 bags of Type "S" Mortar mix or 1 bag Portland cement and 1/2 bag (1/2 cubic foot) of lime or other plasticizer as directed by manufacturer. Listen to mixer, add water if straining. Fill mixer by adding sand and additional water as needed. Ratio = 1:4.67

**For a typical 9 cubic foot mixer:**

Place  $\approx$  5 gallons of water and 10 shovels of sand to the running mixer. Add 2 bags of Type "S" Mortar or 1-1/2 bags Portland cement and 1 - 5 gallon bucket (heaped) full of lime ( $\approx$  3/4 cubic feet) or other plasticizer as directed by manufacturer. Listen to mixer, add water if straining. Fill mixer by adding sand and addi-

tional water as needed. Ratio = 1:4.5 for Type "S" bags - 1: 4 Cement / Lime mixed at the stated quantities.

- 5) When applying material overhead, the mix may be reduced to a 1:3 ratio for a more adhesive property.
- 6) When applying finish textures or appliques, (dash, spray, light trowel or stippled, etc.)

**Formula 6.1****Use to determine the Cubic Foot Capacity of a Mixer  
(Measurements in Inches)**

3.14 X Radius of drum \_\_\_\_\_ X Radius of drum \_\_\_\_\_ X Length of drum  
\_\_\_\_\_  $\div$  1728 = \_\_\_\_\_ Cubic Feet of Drum

**Example from Mixer shown in Figures 6A, 6B and 6C on following page:**

3.14 X 12" x 12" X 24.5"  $\div$  1728 = 6.41 Cubic Feet. Round down to **6** Cubic Foot.

(You will need to round the final answer down since the actual volume of the drum would be derived from inside drum dimensions and would need the area of the mixing paddles, blades, mechanisms and shaft deducted from this formula's derived volume).



Figure 6A - Standard 6 cf mixer  
(See preceding page for formula)



Figure 6C - Measure Drum Length in inches.  
(**24-1/2 Inches** on this mixer)



Figure 6B - Measure Radius in inches  
(**12 Inches** on this mixer - Casing  
Stop used to aid in measuring)

### Example from Mixer shown in Figures 6A, 6B and 6C on following page:

$3.14 \times 12'' \times 12'' \times 24.5'' \div 1728 = 6.41$  Cubic Feet. Round down to **6** Cubic Foot.

(You will need to round the final answer down since the actual volume of the drum would be derived from inside drum dimensions and would need the area of the mixing paddles, blades, mechanisms and shaft deducted from this formula's volume).

## CHAPTER 07 "V" GROOVES AND SEALANT DETAILING

### 1. Separation of ALL Penetrations

- a. Penetrations must be separated with a "V" tool or with the use of a casing bead and backer rod.
- b. The final sealant in the socket created by either method listed above must be

tooled using a sealant spatula.

- c. Proper "V" tooling, sealant socket creation and sealant application is shown below in Figures 7-1 thru 7-14

This "V" groove MUST be cleaned with a damp soft brush while plaster is plastic. This will soften ragged edges of the groove and clean the shoulder of the penetration allowing sealant to adhere.

Figure 7-1 Sealant Socket 3/8" width X 3/8" Deep

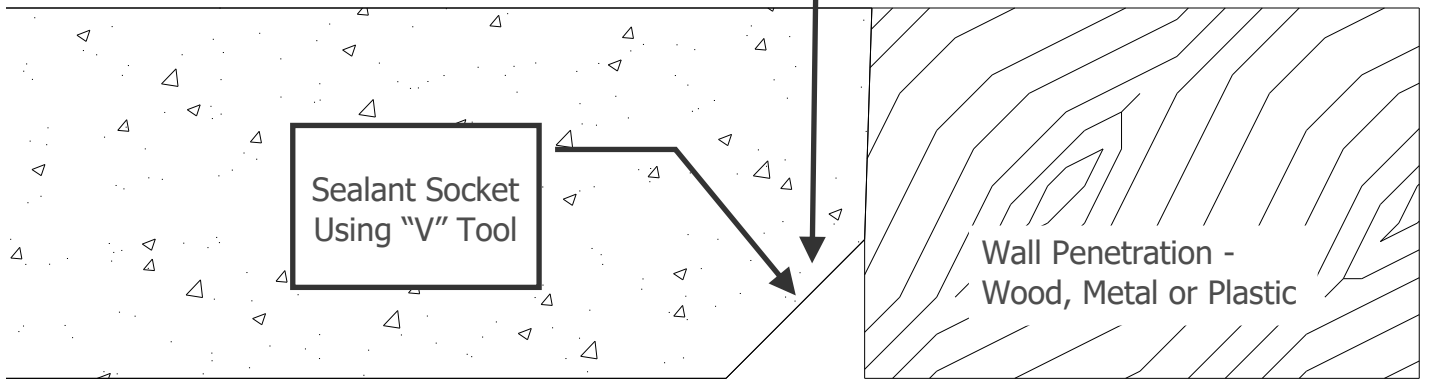

Figure 7-2 Socket Filled with Sealant and Tooled in Place. Sealant should be placed over Prime Coat

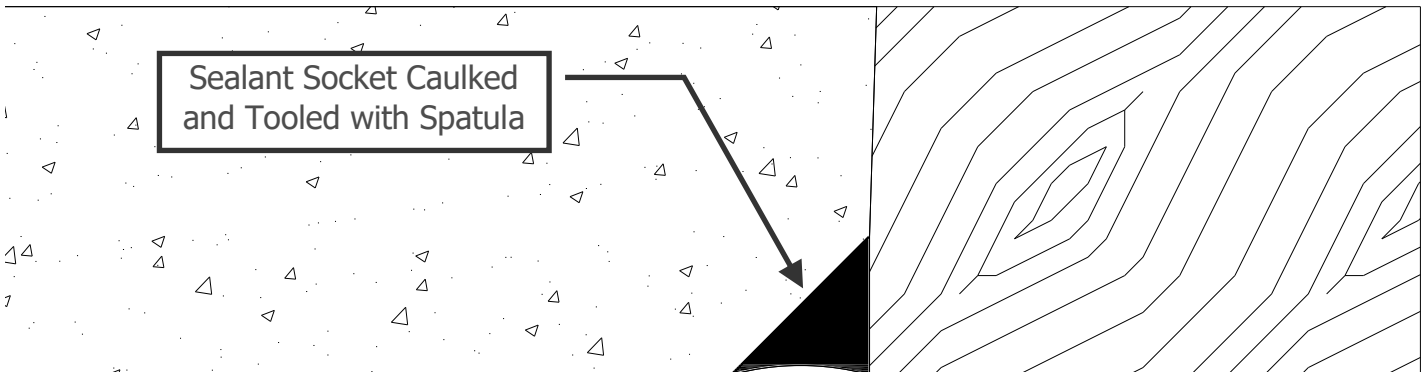



Figure 7-3 "V" tool minimum dimensions. Handle 3/8" x 3/8" x 8". Field fabricate cutting blade from metal banding or steel strapping. Handle made from wood, aluminum or composite material. Tape metal blade to handle with electrical tape. Field fabricated or purchase from the Stucco Institute

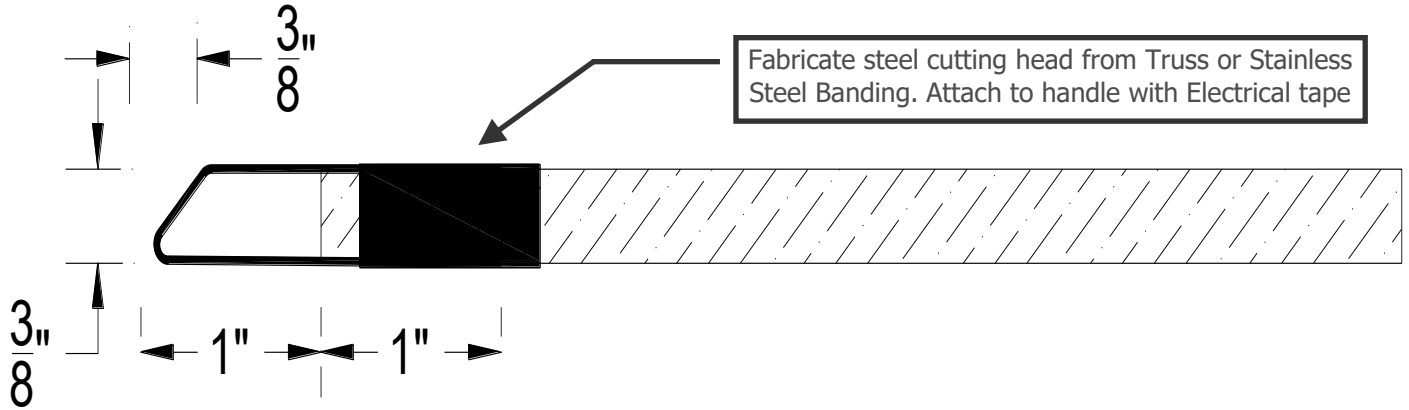

Figure 7-4 Photo of "V" Tool



Figure 7-5 Cutting the Sealant Socket with the "V" tool. Two (2) - 3/16" deep passes are made to ensure a smooth socket



Figure 7-6 Example of Proper "V" Tooling, Brushing, ready for application of Sealant with Spatula



Figure 7-7 Horizontal Sealant Seat created using "V" tool and dampened brush. "V" groove cut AFTER densification of plaster by wall float



Figure 7-9 Brush bristles are angled to smooth the socket seat, smooth over the top edge and clean the shoulder of the penetration

Figure 7-8 After "V" Tooling, the Sealant Socket must be brushed with a brush having dampened bristles. Smooth Edge and Clean Shoulder





Figure 7-10 Application of Approved Sealant



Wall and Socket primed prior to the application of approved sealant. Different sealant color was used in the example for visual contrast and clarity.

Figure 7-11 Sealant Spatulas. Select one with a blade width  $\geq 1/2$ "



Figure 7-12 Spatula presses sealant into socket forming a sealed bond and smoothing the face for final coating applications



Figure 7-13 Photo of Tooled Sealant Socket after Application of Final Coat of Wall Coating





Figure 7-14 Close-Up of Final Application of Tooled Sealant Joint. Joints such as these have remained watertight for decades when installed in this manner. Wall Coating is 12 mils thick minimum.



### Sequence of "V" Tooling, Sealant Socket Preparation and Sealant Application

- i. Apply Cement Plaster to its final wall thickness; 3/4" over StructaLath or 3/8" over Cement Block or Concrete.
- ii. Densify the final base or cover plaster with a "green" open cell float adding water to the plaster mass.
- iii. Cut a "V" using 2 - 3/16 deep passes over wire lath substrates and 2 - 1/8" passes over masonry substrates
- iv. Brush the Sealant Socket to seal the cut, clean the shoulder of the penetrating element, and soften the outside top edge transition.
- v. Prime the wall, using a brush to apply the primer to the sealant socket and penetrating element's shoulder.
- vi. Apply approved sealant in the socket and tool with spatula.
- vii. Apply final coat(s) to obtain the required millage thickness to the wall surfaces.

**CHAPTER 08**  
**OUTSIDE AND INSIDE CORNERS**

Figure 8-0

RODDING OUTSIDE CORNERS





## 1. Dealing with Outside Corners - Vertical or Horizontal

- a. Outside corners are recommended to be rodded over StructaLath that has been simply wrapped around the outside corner. The use of StructaLath premade wire reinforcement is allowed but the final application coat must be rodded to cover the wire corner bead completely. See figures 8-5 - 8-9

### Vinyl (plastic) Corner Beads

- b. Unless the flanges of vinyl corner beads are fully embedded by the plaster - there will be honeycombs or voids behind them acting as collection points for substrate moisture and vapor.
- c. Figures 8-1 shows a typical vinyl corner bead. Unless the flanges are fully encapsulated and the cavity forcefully and deliberately filled, a hollow void will remain behind the bead's nosing. Figures 8-2, 8-3 and 8-4 show the hollow void left by incomplete preparation of the bead's flanges - especially when the nose ground is set off the wall to accommodate 3/4" plaster applications.

Figure 8-1 Typical Vinyl Corner Bead

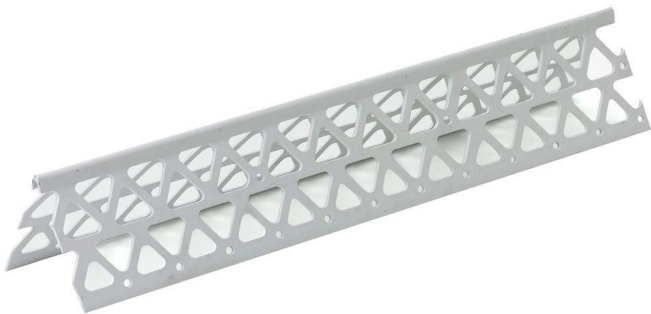

- d. These voids remain a major source of bulk water intrusion and provide vapor collection reservoirs behind the plastered cladding. They must be avoided in all sheathed frame

Figure 8-2 Vinyl Corner Bead with bent coffee stirrer - shown for length



Figure 8-3 - Coffee stirrer shown above slid down into the cavity created by Vinyl Corner Bead's Nosing/Flange Intersection area



wall construction. They alone are responsible for vast damages.

- e. These beads can be properly prepared to eliminate the sub-channel pathway, however the effort to properly prepare ("prepped") them is more time consuming and costly than simply rodding the corners whereby all problems are eliminated.
- f. Even with their flanges properly prepped, their efficacy over framed walls is questionable because of the flange angles created by placing the nosing 3/4" off the wall facing (creating a larger cavity space) makes total encapsulation of the flanges much more difficult.
- g. Therefore, for these and other reasons, they are **not** permitted over any framed wall construction - wood or steel studding.

### **Vinyl (plastic) Corner Beads over Concrete Masonry Units (Blocks) or Concrete Walls.**

- h. Vinyl corner beads are allowed over Concrete Masonry Units (Blocks) or Concrete walls since; (1) they are mounted closer to the wall (minimizing cavity space), (2) vapor or water admitted at the nosing cannot travel behind the cladding since it is solidly adhered (bonded) to the substrate, and (3) the solid mass of cement is not affected by minor water intrusion. Rodding, however, still remains the preferred method.
- i. Figure 8-4 Author demonstrating how the bead must be properly prepped by wiping "thin" (water added) mud (plaster mix) through the flanges from both directions until all backside voids are eliminated. This is performed immediately in advance of the wall plaster. These type of vinyl corner beads are allowed on corners of blocks or

Figure 8-4 - Author demonstrating how to properly "prep" a corner bead to eliminate backside voids. Bead applied to a concrete block wall.

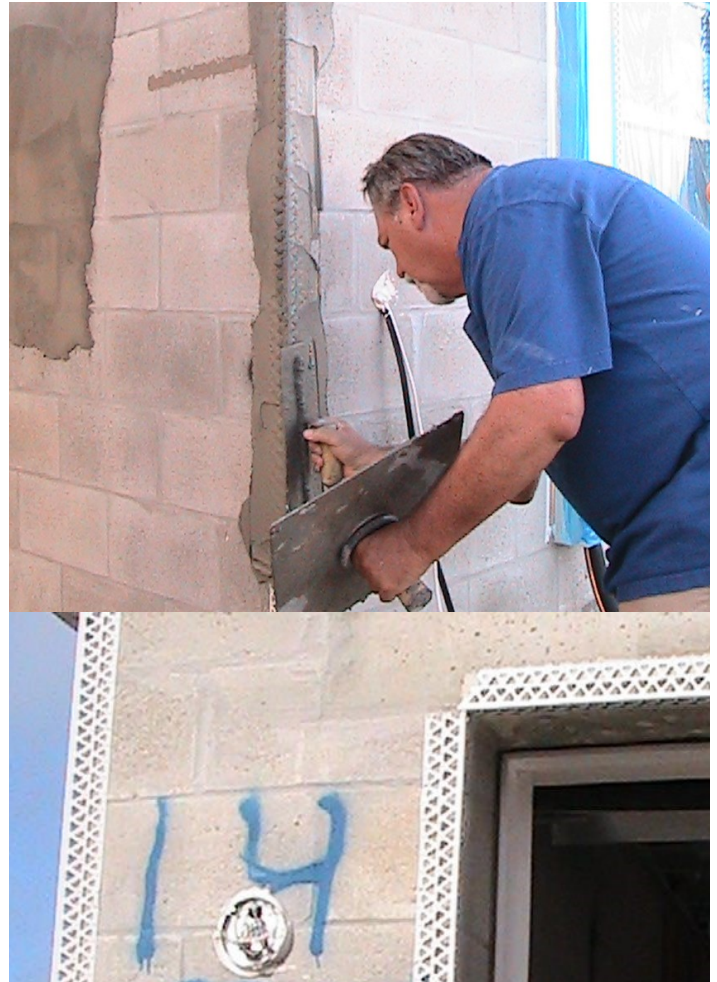

concrete only. They are prohibited over wood frame or steel frame substrates.

### **StructaLath Wire Corner Reinforcement**

- j. Over wood or steel frame substrates StructaLath "V" Truss straight corner reinforcement is allowed to be installed at corners. These are "open wire" reinforcement allowing the wet plaster to freely flow behind its flanges eliminating backside flange voids.



k. The nosing wire is to be set at 3/8" and serves as a ground for the embedment coat a/k/a; "scratch" or "lath" coat. The second (final) 3/8" cover coat must be rodded to ensure the nosing wire (and other parts of the corner wires) are covered with 3/8" of wet plaster assuring their protection from the elements while curing and awaiting the PH to become low enough (<10) for the application of the Drylok Extreme Coating. See Figures 8-5 - 8-10 .

l. This 3/8 coverage is essential for initial and continued protection.

m. Wrapping the StructaLath itself around the corners and rodding both coats of plaster remains the favored and proven application process for all outside corners. See Figures 8-6 through 8-7

Figure 8-5 Preformed Wire Reinforcement



Figure 8-6  
StructaLath cut from a roll and jobsite formed into Outside or Inside Corner reinforcements

Figure 8-7 StructaLath Wire Bent Around Corner as a Continuous Application

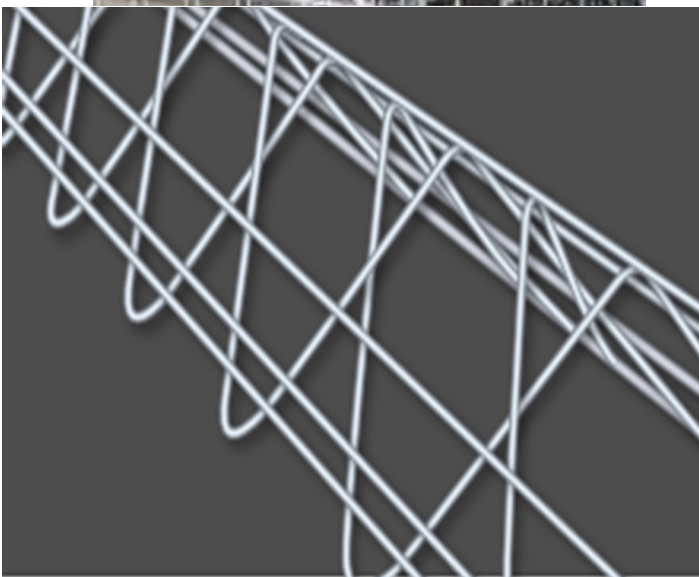

2. Outside Corners over any steel or wood framing MUST be formed using a "ROD" a/k/a "Feather Edge, or "H" Rod. The rod length is closely matched to the corner height (usually an 8' rod).  
See Figures 8-0, 8-8 and 8-9
- a. Rod is held on both wall faces in sequence - using the trowel to force the wet plaster against the Rod embedding the plaster into the wire lath or the previous coat eliminat-

ing all voids. Corner is then wholly composed of solid cement plaster.

- b. As the corner begins to "set", a soft float can be used to "round" the outside corner eliminating sharp corners that may lead to paint "chipping" on the corner.

See Figures 8-8 - 8-23 for rodding processes.

Figure 8-8 Magnesium Featheredge a/k/a Plasterer's Rod or "H" Channel Straight edge. They can be of other shapes such as "L" metal channel sets, etc...



"L" Mortar Screed (Rod) Set.

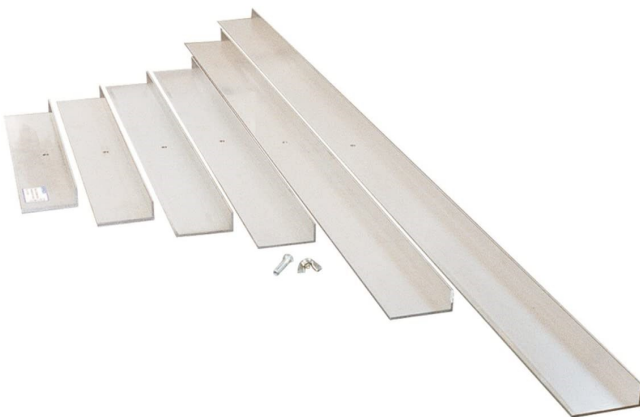

Figure 8-9 Using a Feather Edge Rod to form an External Corner. "Rodding a Corner".

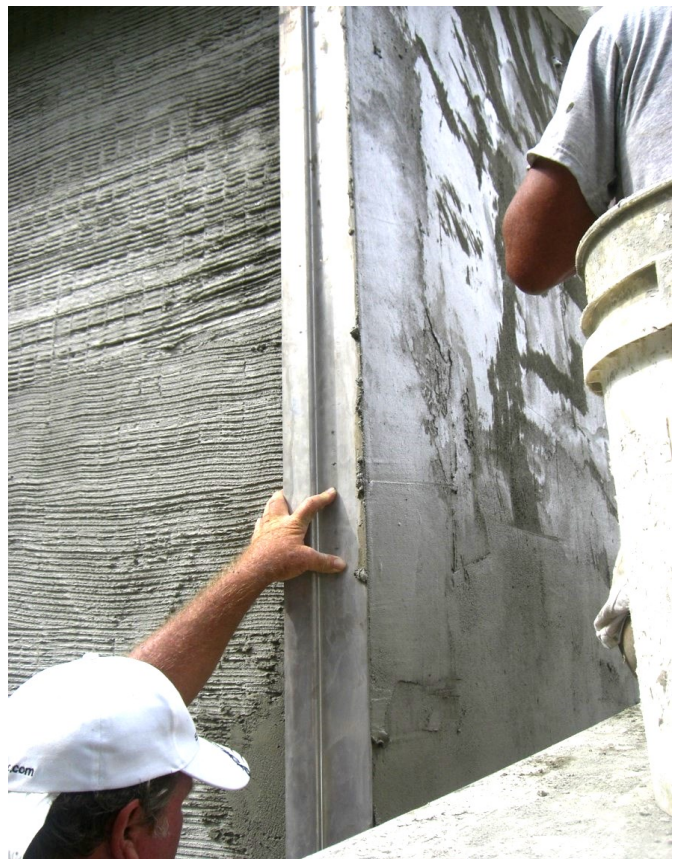



Figure 8-10 Setting a Rod to mud the "arris" (top angle return to the window)



Figure 8-12 Using a Rod to mud the sill to the required slope. (See Detail 06\_06)



Figure 8-11 Floating the Arris and Window Returns. These are to remain floated and then coated with Drylok. No texture, spray or other finishes that impede water drainage permitted.



Figure 8-13 Sill is to be Floated. No texture, spray or other impediments to drainage permitted. See Detail 06\_06 CMU Sill Slope





Figure 8-14 Rod set on Jamb Side of the Window Return. Mudding in the return - top to bottom.



Figure 8-15 Rod "slid off" (upward and outward motion). Trowel removing rod slide-off marks.



Figure 8-16 Densifying; adding water (recharging) using an open cell float to control hydration.



Figure 8-17 Using a soft closed cell float (slide up and down) to gently form a slightly rounded corner.



Figure 8-18 "V" Tooling a sealant seat at a masonry window return



Figure 8-20 Brushing the "V" socket to smooth edges, clean shoulders and seal for application of tooled sealant on block wall return



Figure 8-19 "V" Tooling a sealant seat along the shoulder of a fin window in frame wall



Figure 8-21 Brushing the "V" socket to smooth edges, clean shoulders and seal for application of tooled sealant on frame wall with fin window





Figure 8-22 Finished CMU (concrete masonry unit; a/k/a "block") interface and window returns. Wall face 3/8" thickness, rodded return corners, densified, "V" cut sealant sockets, floated returns, floated wall face (texture or dash finish applied to wall face at this time if desired), corners rounded slightly with soft float. See Detail Series 06 for fenestration details.

Returns and window sill remain floated (no texture)

Ready for Coating and sealants when PH is <10.



Figure 8-23 Finished Fin window over frame wall section. 3/4" thickness, densified, "V" cut sealant socket abuts window (jamb and head) extrusions, floated wall finish (texture or dash finish applied to wall face at this time if desired), corners rounded slightly with soft float. See Detail Series 06 for fenestration details.

Ready for Coating and Sealants when PH is < 10.



3. Inside Corners. Figures 8-24 - 8-26 outline the requirements for inside corners.

Figure 8-24 Inside Corner Construction

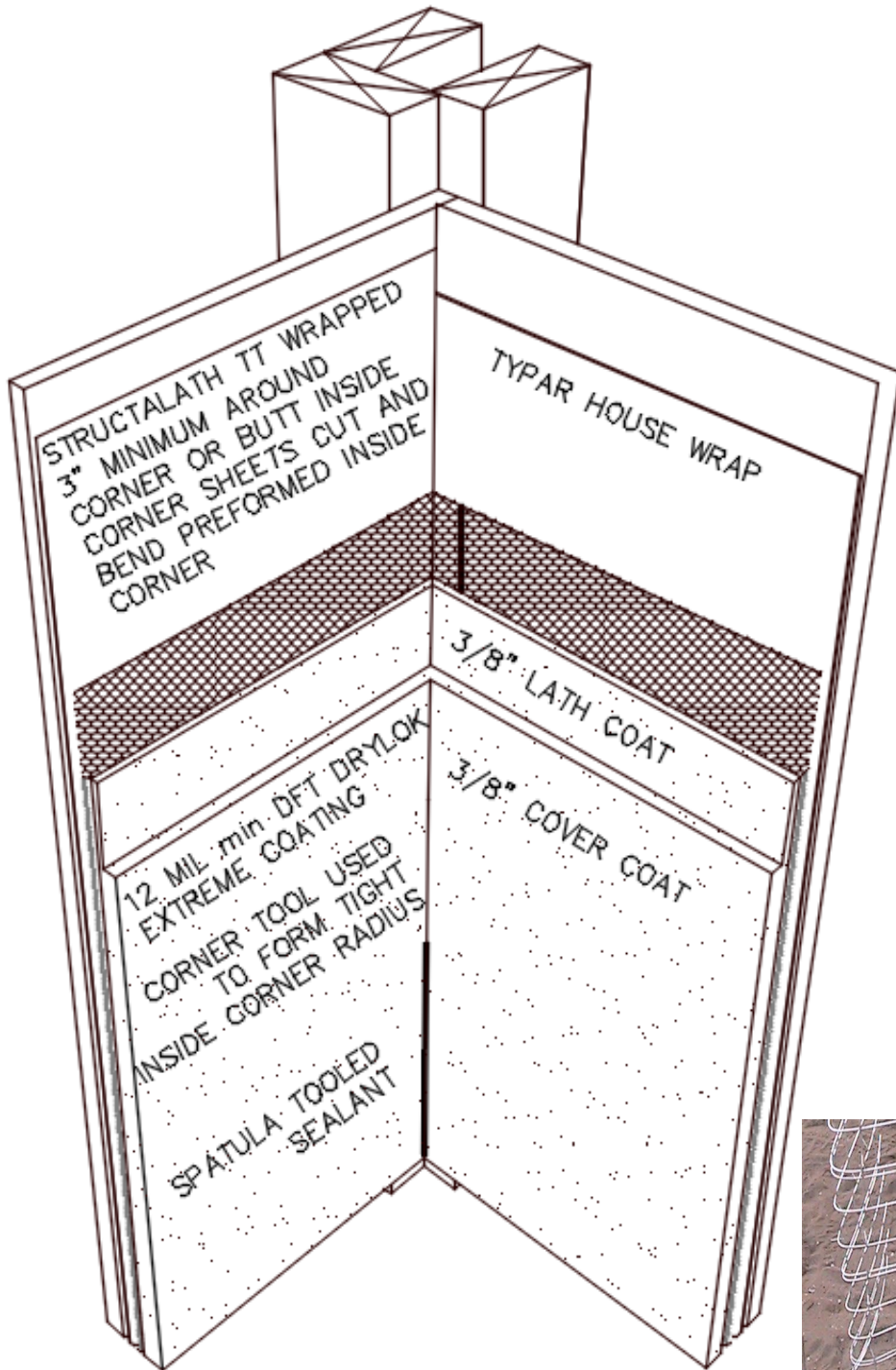

Figure 8-25 Inside Plastering Corner Tool (not an inside Drywall Tool). Corner tool pressure seals and seats the wet cement



Figure 8-26 Properly Tooled Corner. Tight formed radius.



Figure 8-27 StructaLath Jobsite Made Preformed Outside or Inside Corner



## CHAPTER 09 PANEL (CONTROL) JOINTS

1. Unless needed for valid reasons listed below Control a/k/a "Panel" Joints are **NOT** recommended or required by the Sealed Cladding System
  - a. These joints serve two distinct purposes;
  - b. First, they serve as "screeds" to aid in uniform thickness. (See Figure 9-1 and 9-2). This is important when plastering large building facades. It minimizes wavy appearances and "cat faces" (imperfections shown by dimples on the face) on the finished system.
  - c. Second, when using a colored cement finish, they break large wall areas into base "panels" mudded from the same mixer load in order to provide a uniform suction so the final 1/8" finish "color" coat (applied after the base cures) dries evenly preventing a blotching or mottling appearance.

Additionally, when using 1/8" finished colored coats, the plasterers need a stopping point for the colored cement finish coat. Blending into a coat that was applied the previous day will cause a wall to have color differences, so, stopping at one side of a vertical joint and restarting on the other side will hide unsightly coloring blends or

Figure 9-1 Using a Featheredge Rod to control the plaster thickness by screeding to the joint.



Figure 9-2 Setting "Dots" to a line for Dot-and-Screed straightening. Alternate to control joint screeding.



blotches. Simply put, a slight difference in color on either side of the joint will not be noticed, but if the two coats were "blended" together with a cold joint, it would be noticeable.

- d. The Sealed Cladding System uses a waterproof coating to form the finish coat (not an 1/8" color cement coat) so all reasons related to control joints and "color curing" of the cement are of **no consequence** whatsoever.
2. Control Joints do not prevent or manage wall cracking. This misconception has prevailed for many years within our industry. Noted Professional Engineer and Stucco expert; John Bucholtz wrote over a decade ago:

"CONTROL JOINTS - THE TRUE STORY (Bucholtz – Volume 227 ) *excerpt....*

First, CONTROL JOINTS DO NOT PREVENT CRACKS IN STUCCO.

Second, CONTROL JOINTS CREATE REAL SOURCES OF WATER INTRUSION.

Third, CONTROL JOINTS ARE A SHEER WASTE OF MONEY WHEN INSTALLED TO CONFORM TO SOME MYTHICAL DIMENSION THAT HAS NO BASIS IN FACT.

There has been not one nickel's worth of research or scientific investigation of the need for control joints to prescribe given areas. "

- a. Subsequent to this publication, two independent full scale wall testing

models with various control joint installation methods were constructed, tested and monitored. These tests were conducted in Houston and Las Vegas by two separate associations.

- b. Results were examined and published and, although experts may argue the miniscule details of the miniscule crack patterns, there was no significant difference in cracking patterns regardless of how the joints were installed; staples, nails ties, etc..., or whether the flanges were attached on one side with fasteners or ties, whether the flanges were in front of the lath or back, whether the lath was continuous or discontinuous behind the joints or whether there were NO control joints in the panel at all.
- d. Other than aesthetics, there are three reasons for control joints; (1) to provide panels with vertical stopping areas filled with basecoat material from the same mixer batch, (2) to control the thickness of the cement plaster and (3) to aid in providing a flat face finish by using them as "screeding" points - rodding to them to provide a flat, true, plane.
- e. Reasons (1) and (2) are critical for successful application of the 1/8" finish color cement coat that dries uniformly (previously discussed).



- f. Reason (3) is of value on jobs with large surface areas or aesthetic value.
- g. For residential walls, usually less than 10 feet in height and less than 40 feet in length, there is simply no need to use them - plasterers do not have difficulty keeping thickness and flatness managed on vertical walls of these dimensions.
- h. The reason is simple; with limited length and height walls, application is in short confined dimension and the experienced plasterer will have no difficulty maintaining a flatness profile, and there are sufficient screed points at the soffit and the base of the wall to assure uniform thickness.

- i. Accordingly, there is simply no need for them in most residential or light commercial projects.

### Spacing of Control (Panel) Joints as Screeds

- 3. If control (Panel) Joints are to be used (usually on high or long walls) to break up the appearance and/or used as screeds, their spacing should be determined by aesthetics or plastering method. See Figure 9-3
  - a. When used for screeds to ensure wall flatness, vertical screeds should be set to a horizontal measurement of at  $\approx 14-16$  feet on center (using an 8' rod) and  $\approx 18-20'$  feet on center (using a 10' rod).

Figure 9-3 Large Commercial Façade. Control Joints set for screeds. Verticals spaced  $\approx 14'$  apart for use of 8' Rod screeding. Red bar represents 1st rod lift, Green bar represents 2nd lift. Horizontal screeds usually set at floor level or equally spaced. If no Control Joints are desired, use dot and screed method. Verticals unbroken. Joints sealed. "V" tool edges. See Details 05\_01 and 05\_02 when Control (Panel) Joints are used.

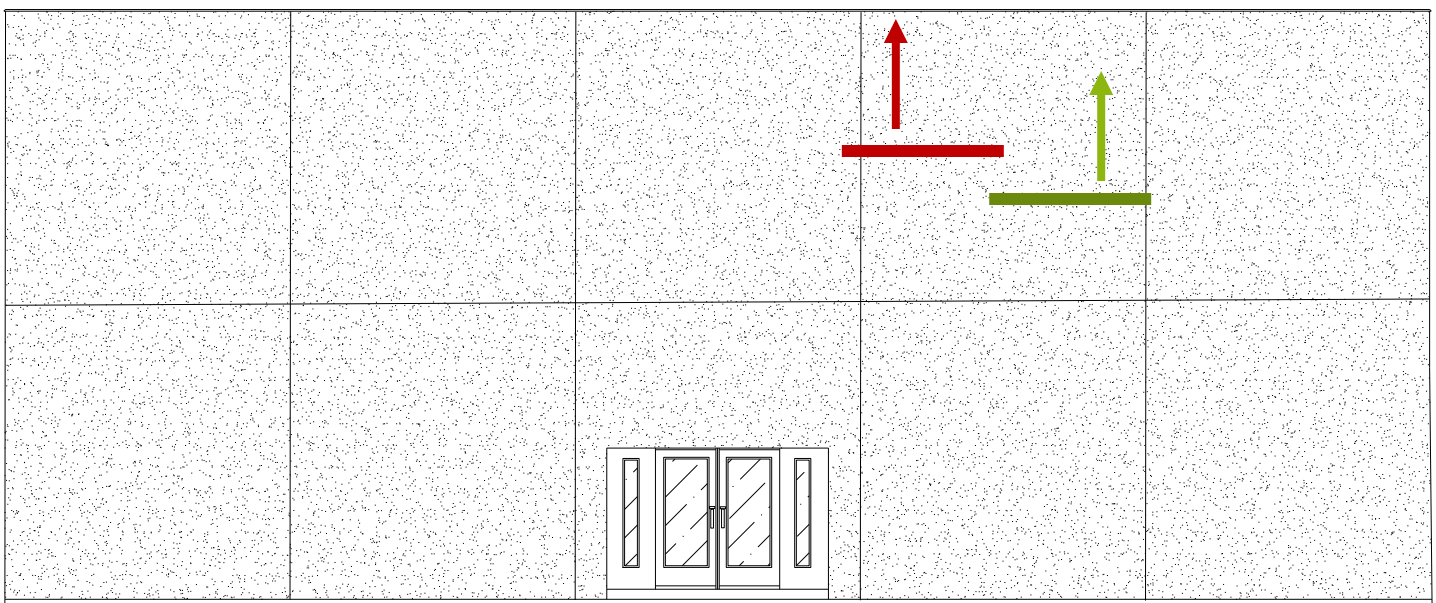

- b. The plasterer sets the rod on one edge and screeds to the middle of the panel, then sets the rod on the other end and screeds back to the middle of the panel.
- c. Horizontal Joint Screeds are usually set at floor or story levels.
- d. If larger areas are needed or Control Joints are undesirable, the dot and screed method can be used.
- e. Length to width ratios or minimum / maximum panel sizes are not to be factored. Control Joints sever no other purpose than screeding and aesthetics.

Figure 9-4 Shows the effects of Control Joints not installed per Details 05\_01 and 05\_02. Separation, Cracking and Water Intrusion destroying the system. These alone cause millions of dollars of damage unnecessarily. When properly installed, "V" tooled and coated, they pose no problem but should not be used unless needed.



### Control Joints **MUST** be Installed per Details 05\_01 and 05\_02

4. Failure to install Control Joints or other Accessories properly will cause failure.
5. Refer to Figures 9-4 and 9-5

Figure 9-5 Shows the effect of Vertical and Horizontal Corner Bead not properly prepped by the plasterer. Water reservoirs and channels allow water and vapor distribution along the back flange of the beading corners. Eliminating the bead and Rodding the vertical and horizontal corners eliminate the problem. See Chapter 8 - "Corners"



## CHAPTER 10 COATINGS AND SEALANTS

### Exterior Coating

1. The exterior coating is the most critical step in the Sealed Cladding System's process. Although the exterior wall coating (incorrectly termed "painting") is frequently installed by a painting contractor, it is best installed by the Sealed Cladding System contractor since it is an extension of the cement plaster system - it is the final system coat.
2. Painting contractors can bid the exterior doors, trim and other façade components - but the wall and its sealants are usually better left under a single contractor - usually the plasterer.
3. Thickness of material, tooling of joints, spatula's (similar to a trowel) and other aspects of installing proper coatings are extensions of the knowledge sets already possessed by plasterers.
4. Regardless of who performs the work - the competency and quality of the coating and sealant's installation is the make-or-break aspect of the Sealed Cladding System's ultimate performance.

### UGL DRYLOK EXTREME

5. UGL will warrant their product to remain waterproof for 15 years when applied according to the manufacturer's installation instructions. (see warranty for specific details). UGL Instructions are included in this chapter and in the Appendix. When coating new bare cured Portland Cement Plaster, these provisions must be followed:
  - a. Do not apply in rain or when rain is expected

within 24 hours. Air and surface temperatures must be 50 degrees F (10 degrees C), or higher.

- b. Do not allow DRYLOK EXTREME to freeze.
- c. Use only with adequate ventilation. Do not breathe vapors or spray mist. Wear properly fitted NIOSH Approved respirator during and after application. Follow respirator manufacturer's instructions for proper use.
- d. Stir DRYLOK EXTREME thoroughly **before** and **during** application.
- e. **Do not thin** DRYLOK EXTREME.
- f. For tinting, use alkali-proof universal tinting colorants. Use only 50% of color normally recommended. Do not use more than 2 Fl. Oz. of colorant per gallon.
- g. Ensure that substrate is sound and free of dust, dirt, paints, oils, bonding agents or other contaminants that could impair bond of the coating.

### PH of Cement Base prior to application

- h. PH is measured on a scale from 0 (acid) to 14 (alkaline) with a balanced (neutral) PH of 7. Freshly applied cement plaster is highly alkaline having a PH of  $\approx 12$ . Before application of the coating, the cement plaster needs to "cure" to a point where the PH is less than 10.
- i. The most common way to test the PH level is with a PH pencil - obtained from a local paint store or on-line. To do a field test, moisten the surface with distilled water (not tap water) using a small hand pump sprayer, then mark an "X" on the dampened surface with a PH pencil. The resulting color is matched to the chart to determine the PH level. (See Figure 10-1)

Figure 10-1 PH Pencil. Wet a small spot on the wall with distilled water, draw an "X" with the marker and match the color to the appropriate color swatch to determine the PH.



### Do not paint too soon!

- j. Applying paint early can create several problems at the chemical level:
- ◆ **Lime or alkali burn.** This causes color loss, bleaching, chalkiness, or other deterioration of the coating pigments.
  - ◆ **Efflorescence.** Moisture inside a wall can carry salts to the surface, leaving behind white deposits or crystals. With a highly permeable coating, the salts may bleed through. Less permeable coatings can trap the deposits and cause delamination, or separation between the coating and surface.
  - ◆ **Saponification.** High alkalinity and moisture can also attack the coating resin chemically causing blisters, brittleness, or a soapy texture. (In fact, 'sapo' is the Latin word for soap.)

### Tools, Brushes and Spraying Equipment

6. For roller and hand application use standard 3/4" - 1-1/4" Nap Rollers and quality Synthetic Bristle brushes. Stainless Steel Sealant Spatulas.

7. For Airless Spraying:

- ◆ **1 to 15 gallons**  
Use Graco® Magnum Pro X21 (Part # 17G182) or larger Graco® sprayer. Remove gun and manifold filters prior to spraying. Use Graco® .019 RAC True Airless tip (TRU-419 8" fan pattern or TRU-519 10" fan pattern). Spray pressure 2200 - 2500 psi. Hold gun 12" from surface when spraying. Spray cross hatching patterns (north/south then east/west) with two coats, building to a 14 - 16 wet mil thickness.
- ◆ **17 to 30 gallons**  
Use Graco® 210es (Part # 261-830) / Graco® 390 (Part # 17C310) or larger Graco® sprayer. Remove gun and manifold filters prior to spraying. Use Graco .019 True Airless tip (TRU-419 8" fan pattern or TRU-519 10" fan pattern). Spray pressure 2200 - 2500 psi. Spray cross hatching patterns (north/south then east/west) with two coats, building to a 14 -16 wet mil thickness.
- ◆ **31+ gallons**  
Use Graco® Ultra Max II 490 (Part #17C327) or larger Graco® sprayer. Remove gun and manifold filters prior to spraying. Use Graco® .021 True Airless tip (TRU-421 8" fan pattern or TRU-521 10" fan pattern). Spray pressure 2200 - 2500 psi. Spray cross hatching patterns (north/south then east/west) with two coats, building to a 14 to 16 wet mil thickness.
- ◆ **All Applications Using Spray Equipment**  
Back brush or Back roll (using 3/4" nap cover) the first coat to fill all pores and pinholes. Give first coat 3 hours to dry, and then apply a second coat. Back brush or Back roll second coat as above working DRYLOK® Extreme into the pores of the masonry and making sure to fill all pores and pinholes.



- a. Apply DRYLOK EXTREME coating directly on to bare stucco.
- b. Two coats shall be applied at a rate of 75-100 SF/Gal. (approximately 13-21 WFT – 330-533 microns) Allow first coat to cure 3 hours, then apply second coat by brush, spray or roller. Maximum cure and dry times will be prolonged when humid and damp or cooler conditions are present.
- c. If desired (but not necessary), for dark tinted colored decorative accents, trims or walls, a third top coat of high quality Acrylic Latex can be after 24 hours.
- d. Examine finished surface after two coats and inspect for any open pores or pinholes. spot-treat if needed.

For updated instructions, tips and additional questions, visit [www.ugl.com](http://www.ugl.com).

### Sealants

8. The use of high quality sealants properly tooled into place is a critical link in any exterior wall's waterproofing ability.
9. High Grade Polyurethane Sealants are the recommended choice. Products such as; Sikaflex 201, MasterSeal NP1, Tremco Vulkem 116 , Loxon S1, are common brands employed and can be used as comparison for approved equals.

### Sequence of installation

10. The Sequence of installation is:
  - I. Install 1st coat. Brush all sealant sockets, "V" grooves, interfaces, inside corners and penetrations.
  - II. Install and tool all sealants in sockets, grooves and around all penetrations.

III. Install 2nd Coat. Trim all angles.

Refer to Exhibits \_\_\_\_

Figure 10-2 Brush Drylok Extreme into all "V" Groove Sealant Socket Seats, Around all Penetrations and along all Shoulders or Stops.



11. Brushing all socket seats ("V" grooves) with Drylok Extreme is usually performed first. The coating dries quickly allowing the Sealant to be installed and tooled. The Sealant then is afforded drying time while the 1st coat of Drylok Extreme is rolled or sprayed on the wall areas. This sequence can happen simultaneously if desired, i.e., the wall priming can be installed first, brushing the sealant socket seats, penetrations, etc. and then the sealant be applied and tooled immediately following.

Figure 10-3 After priming socket seat, apply Sealant and Tool with Spatula



Figure 10-4 Apply 1st Coat Drylok Extreme. Roll or Spray according to the application processes and thickness as described in previous chapters



Figure 10-5 Apply 2nd Coat of Drylok Extreme. Roll or Spray according to the application processes and thickness as described in previous chapters





12. The coating, its application and thickness is the same as required by other coating manufacturers for exterior above grade waterproofing.

### DEEPER TINTS

12. If deeper tints are needed for aesthetics, the two coats of Drylok Extreme can be top coated with any Acrylic Latex Exterior paint. Thickness of the top coat should follow the manufacturer's recommendation which usually will require 2-3 mils for color top coat coverage.

---

Figure 10-6 One of the walls finished and ready for full scale testing and modeling.



## CHAPTER 11 DRAWINGS AND DETAILS

### Sealed Cladding System - Index of Details

#### 01 Roofing Intersections

- 01\_01 Roof to Wall Isometric of Kickout Flashing
- 01\_02 Kick Out Flashing Isometric Interface

#### 02 Foundation Termination

- 02\_01 Foundation Screed Termination
- 02\_02 Foundation Casing Termination
- 02\_03 Foundation Masonry Wall to Footing

#### 03 Penetrations, Wraps, Transitions and Terminations

- 03\_01 Dryer Vent Penetration
- 03\_02 Ceiling to Wall Interface
- 03\_03 Soffits or Beam Wraps "L" Bead
- 03\_04 Fascia / Soffit Rodded Interface

#### 04 Midwall Transitions

- 04\_01 Midwall Screed Transition
- 04\_02 Midwall Casing Transition
- 04\_03 Midwall Smooth Transition

These Drawings are placed here for identification and use. These AutoCAD files are available for download  
[www.SealedCladdingSystem.com](http://www.SealedCladdingSystem.com)

#### 05 Accessories

- 05\_01 Panel (Control) Joint Installation
- 05\_02 Panel (Control) Joint Isometric

#### 06 Fenestration Flashings

- 06\_01 Fin (Frame) Window Installation - Integral Receiver
- 06\_02 Fin (Frame) Window Installation - Shouldered Receiver
- 06\_03 Jamb Interface - Casing Separation
- 06\_04 Self Adhered Fin Interface with WRB
- 06\_05 Flange (Masonry) Installation with Buck Sealant
- 06\_06 CMU Sill Slope Requirements

#### 07 Miscellaneous

- 07\_01 Soffit Detail
- 07\_02 Self Adhered Flashing Door and
- 07\_03 Folding Corners
- 07\_04 Ledge or Shelf

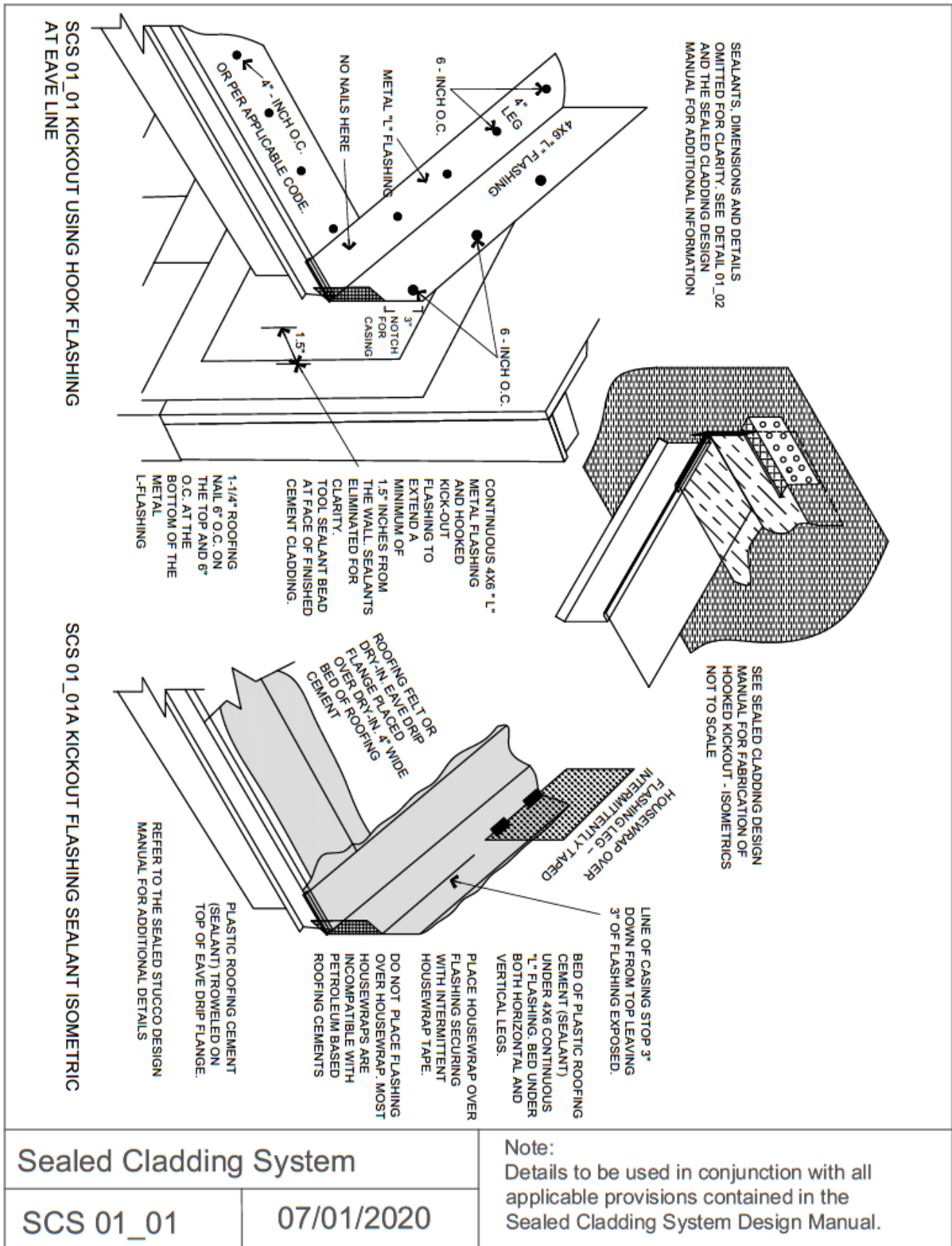

SCS 01\_02 ROOF KICKOUT INTERFACE

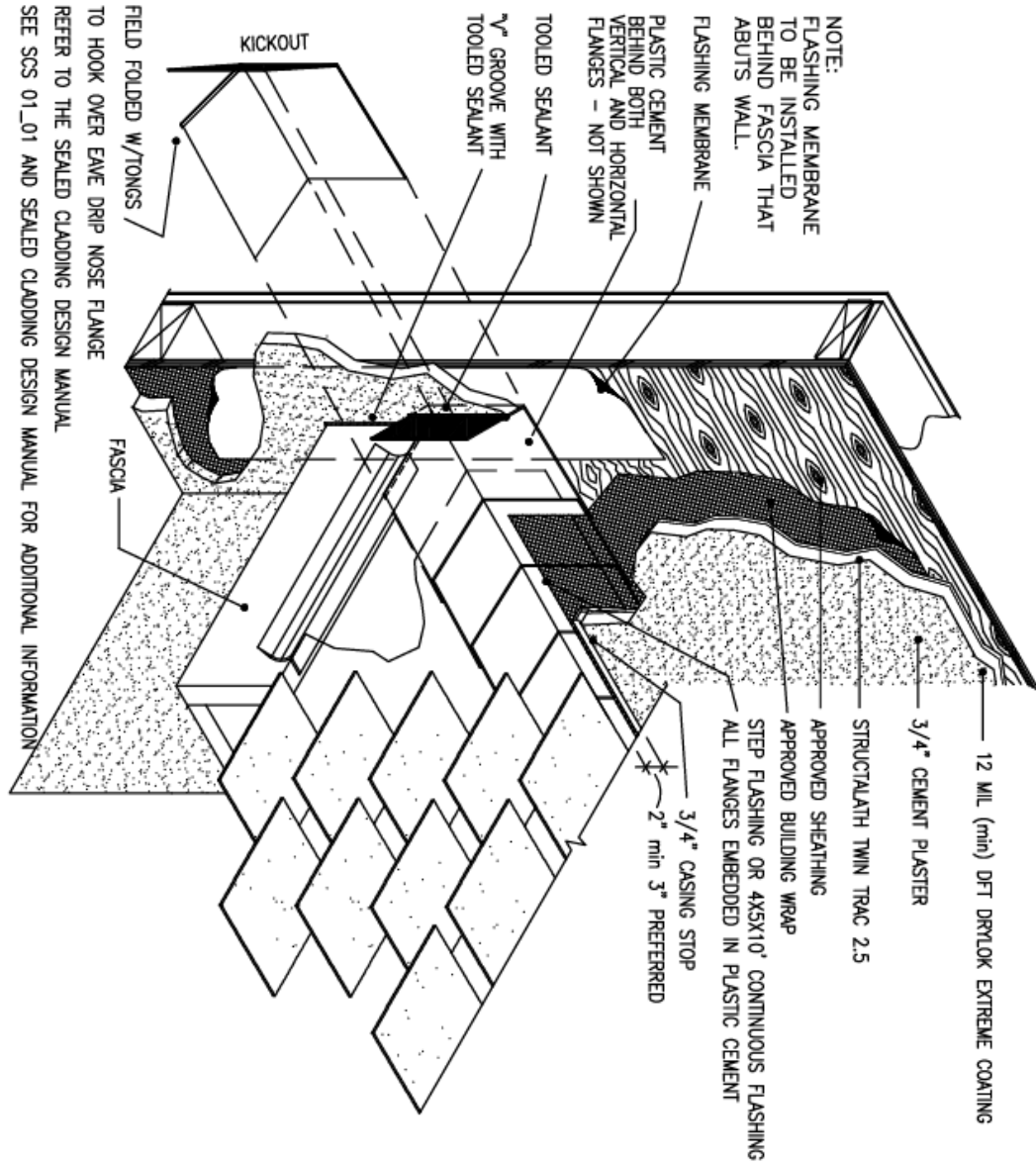

Sealed Cladding System		Note: Details to be used in conjunction with all applicable provisions contained in the Sealed Cladding System Design Manual.
SCS 01_02	07/01/2020	

SCS 02\_01 FOUNDATION SCREED TERMINATION

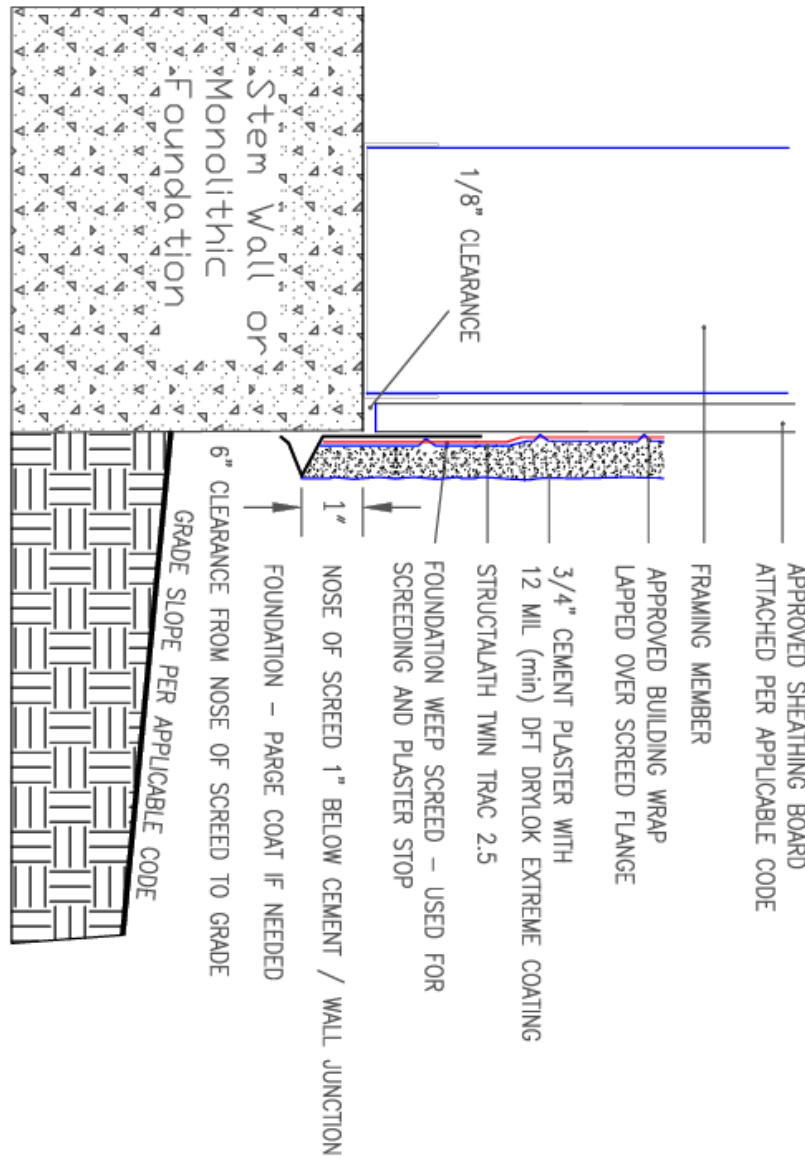

Sealed Cladding System		Note: Details to be used in conjunction with all applicable provisions contained in the Sealed Cladding System Design Manual.
SCS 02_01	07/01/2020	

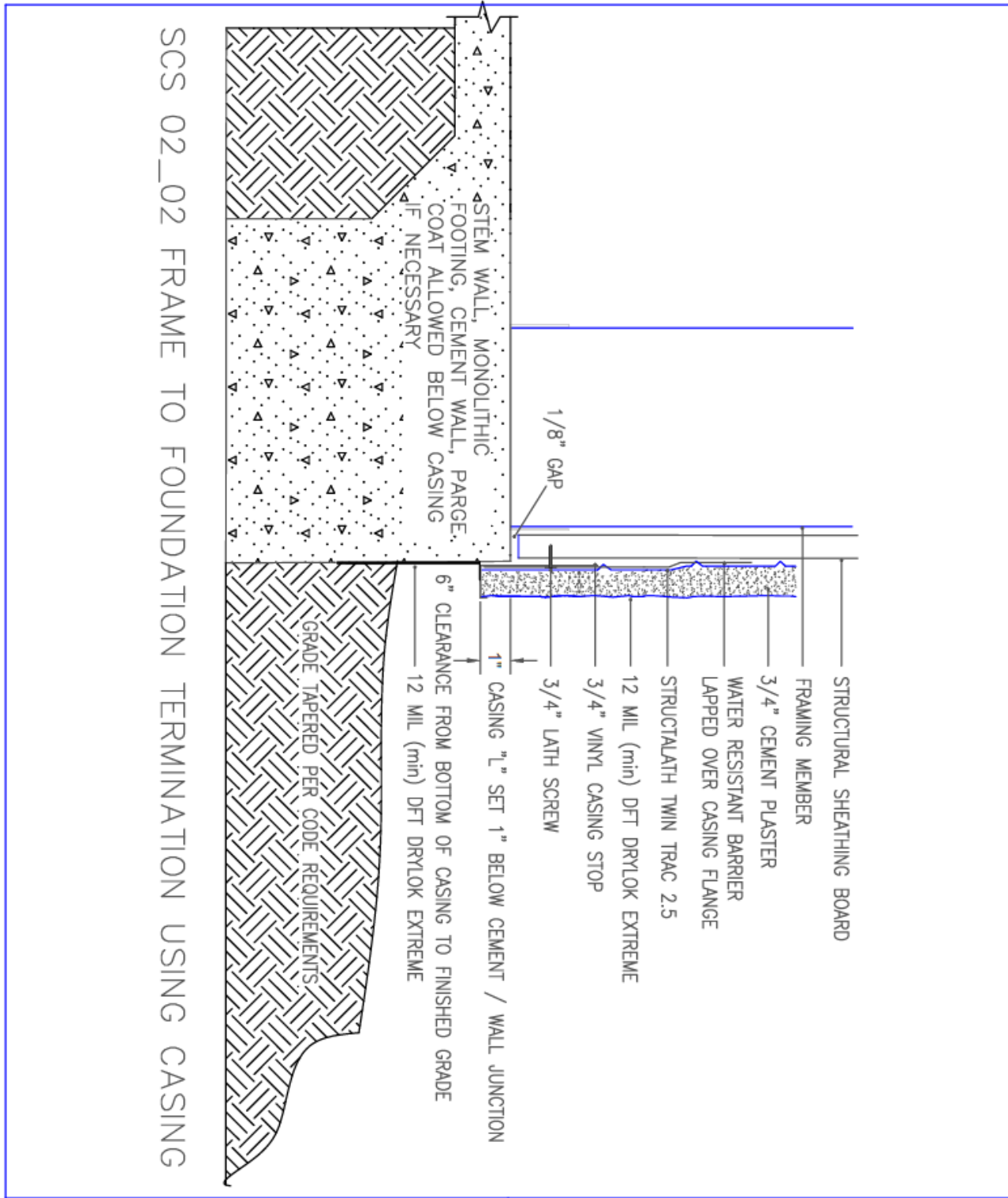

<b>Sealed Cladding System</b>		<p>Note: Details to be used in conjunction with all applicable provisions contained in the Sealed Cladding System Design Manual.</p>
SCS 02_02	07/01/2020	



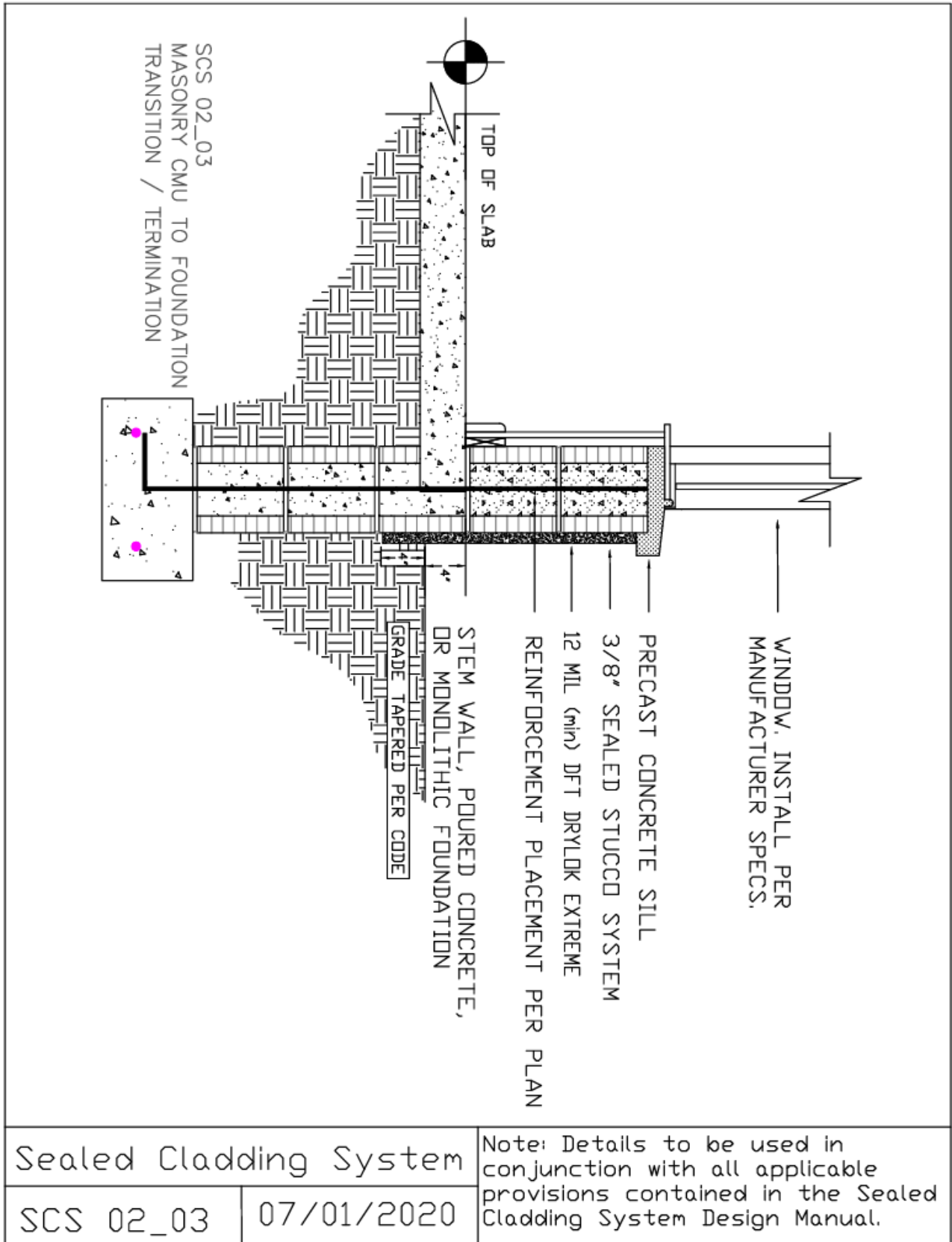

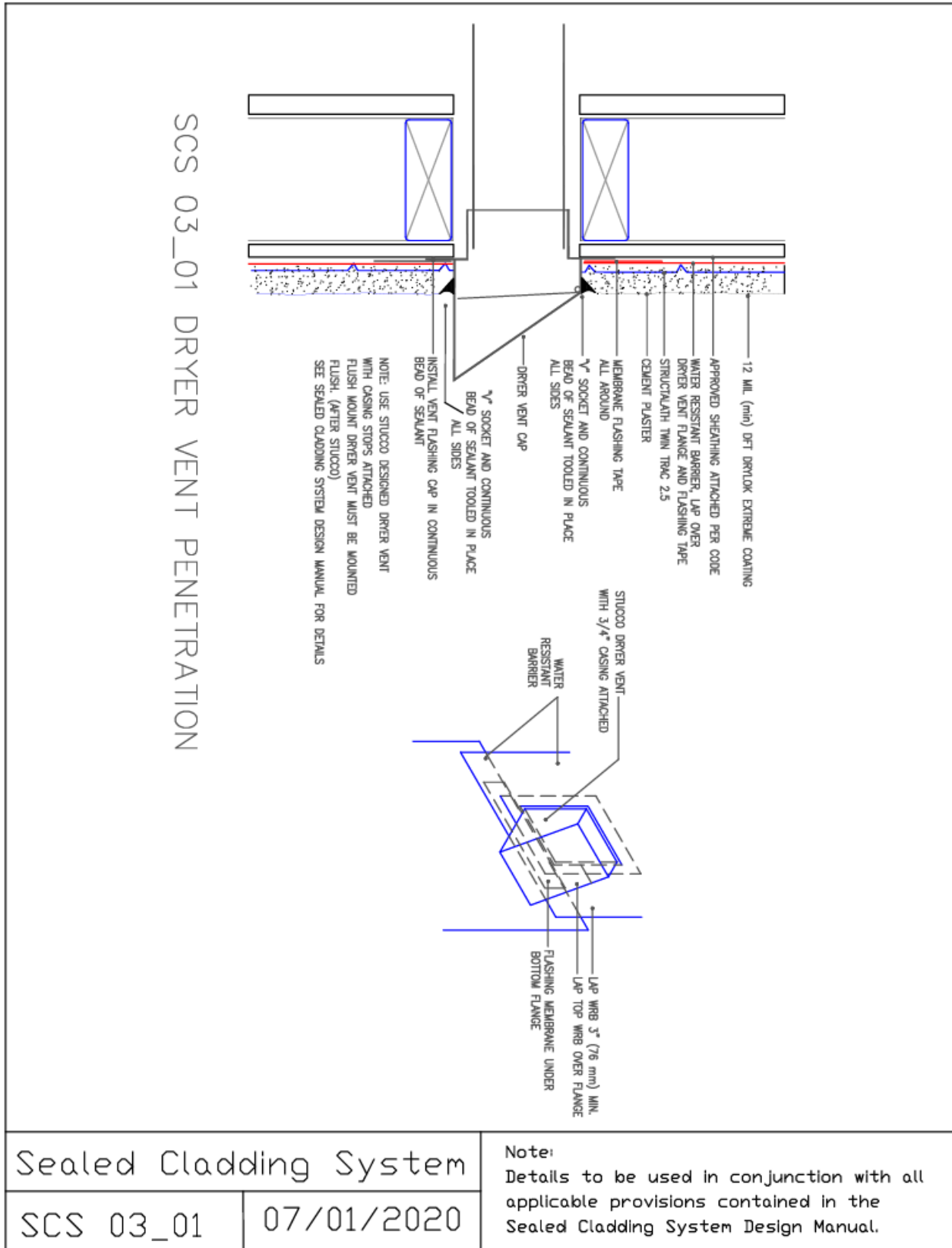

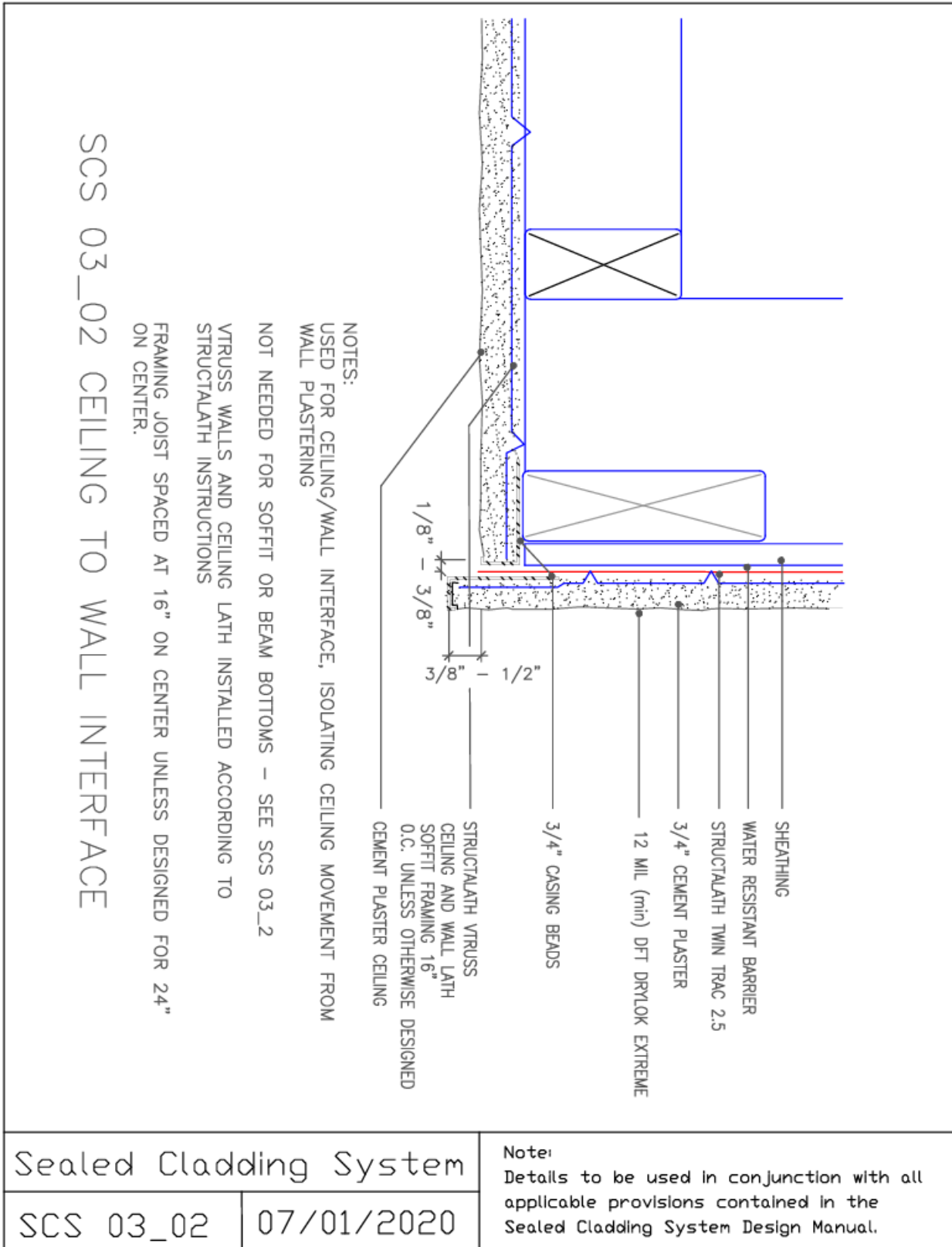

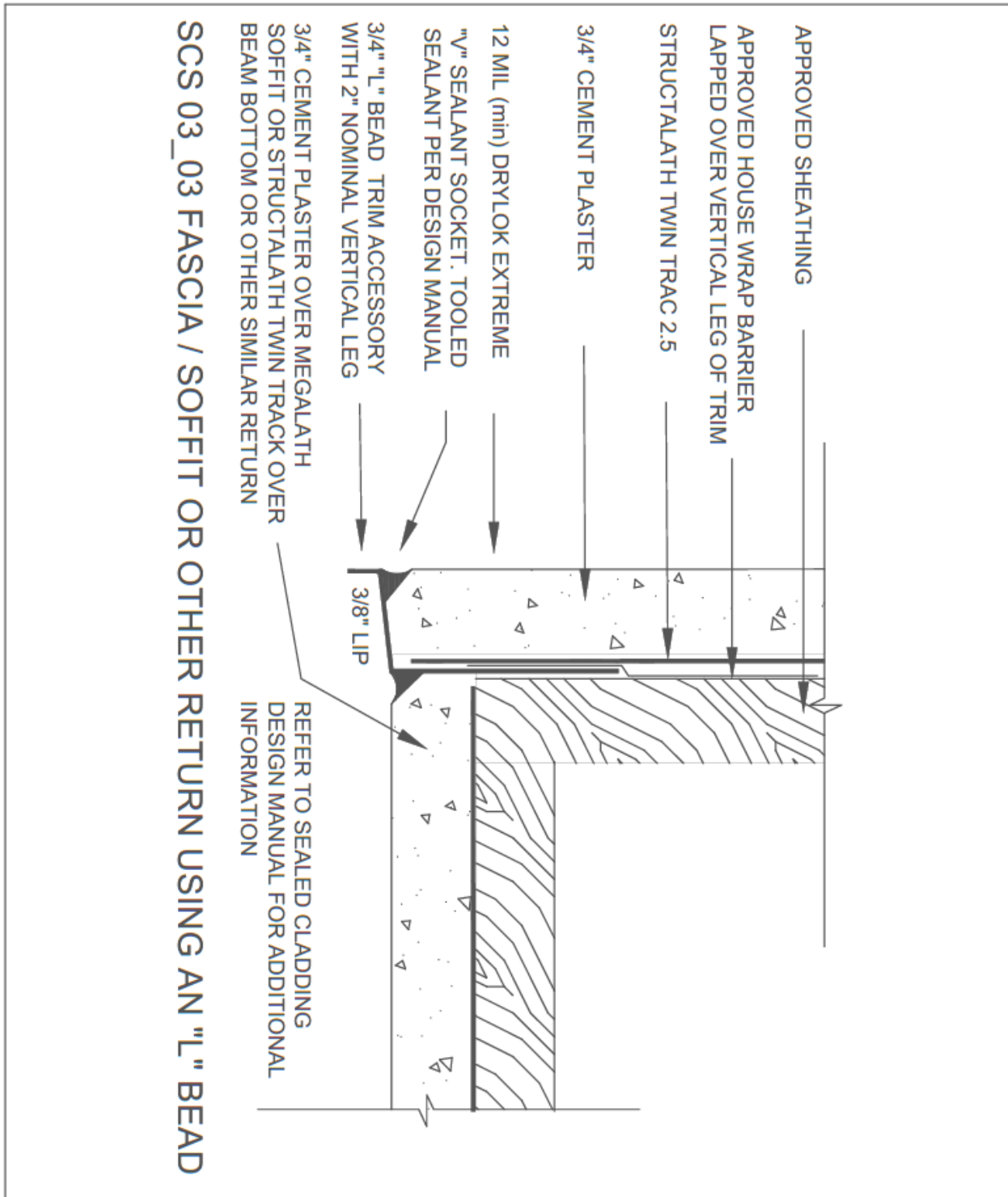

**SCS\_03\_03 FASCIA / SOFFIT OR OTHER RETURN USING AN "L" BEAD**

Sealed Cladding System		<p>Note: Details to be used in conjunction with all applicable provisions contained in the Sealed Cladding System Design Manual.</p>
SCS -03_03	07/01/2020	



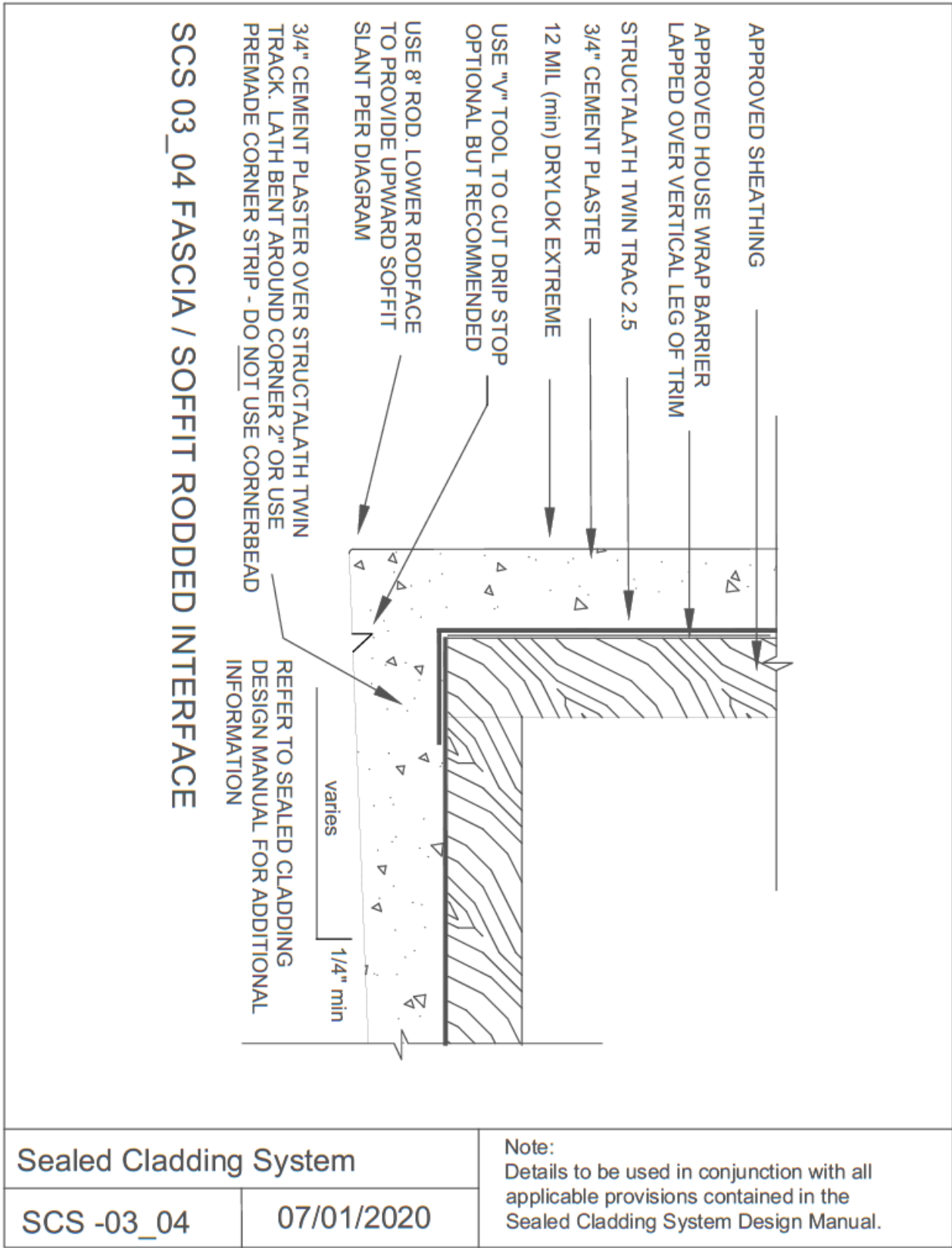

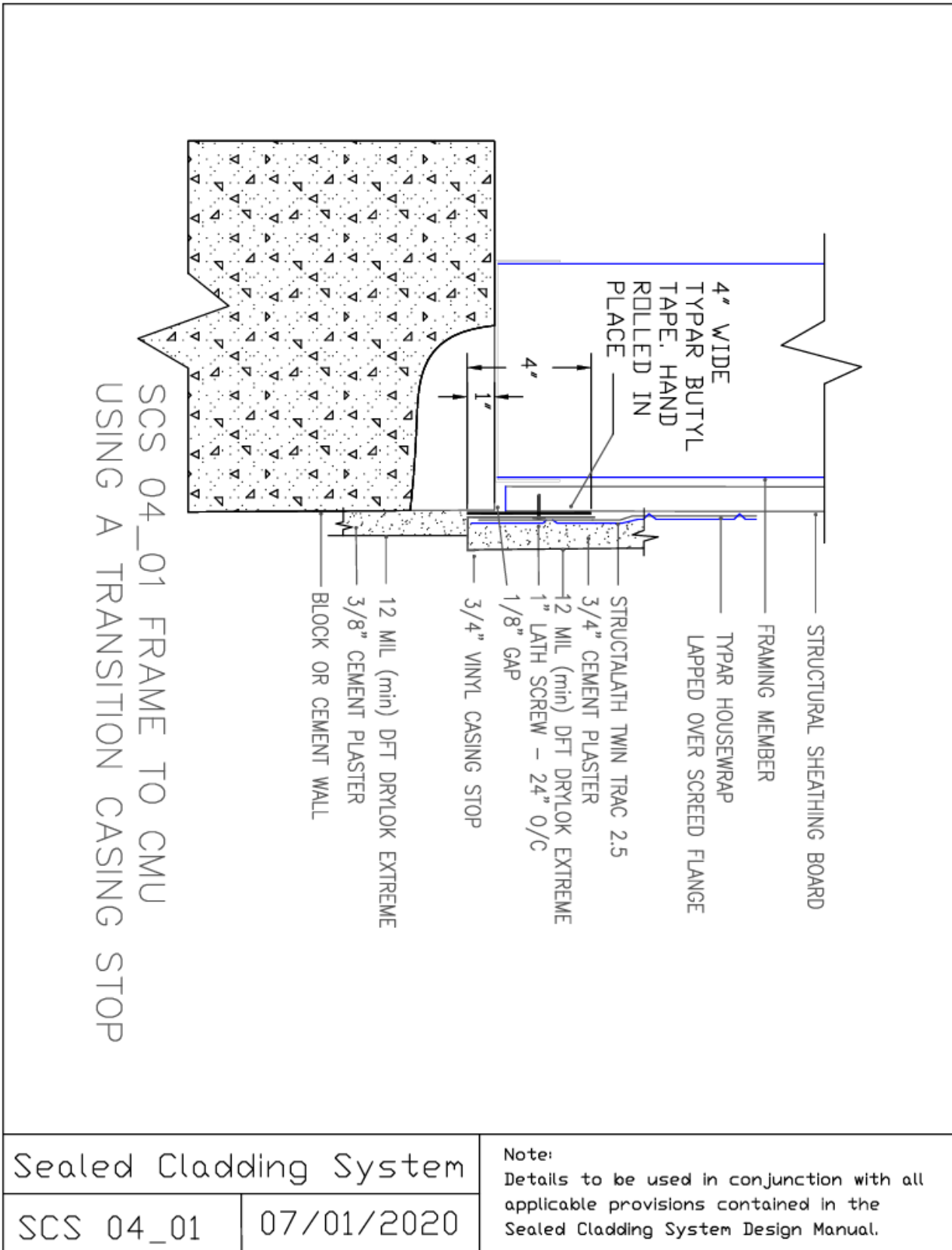

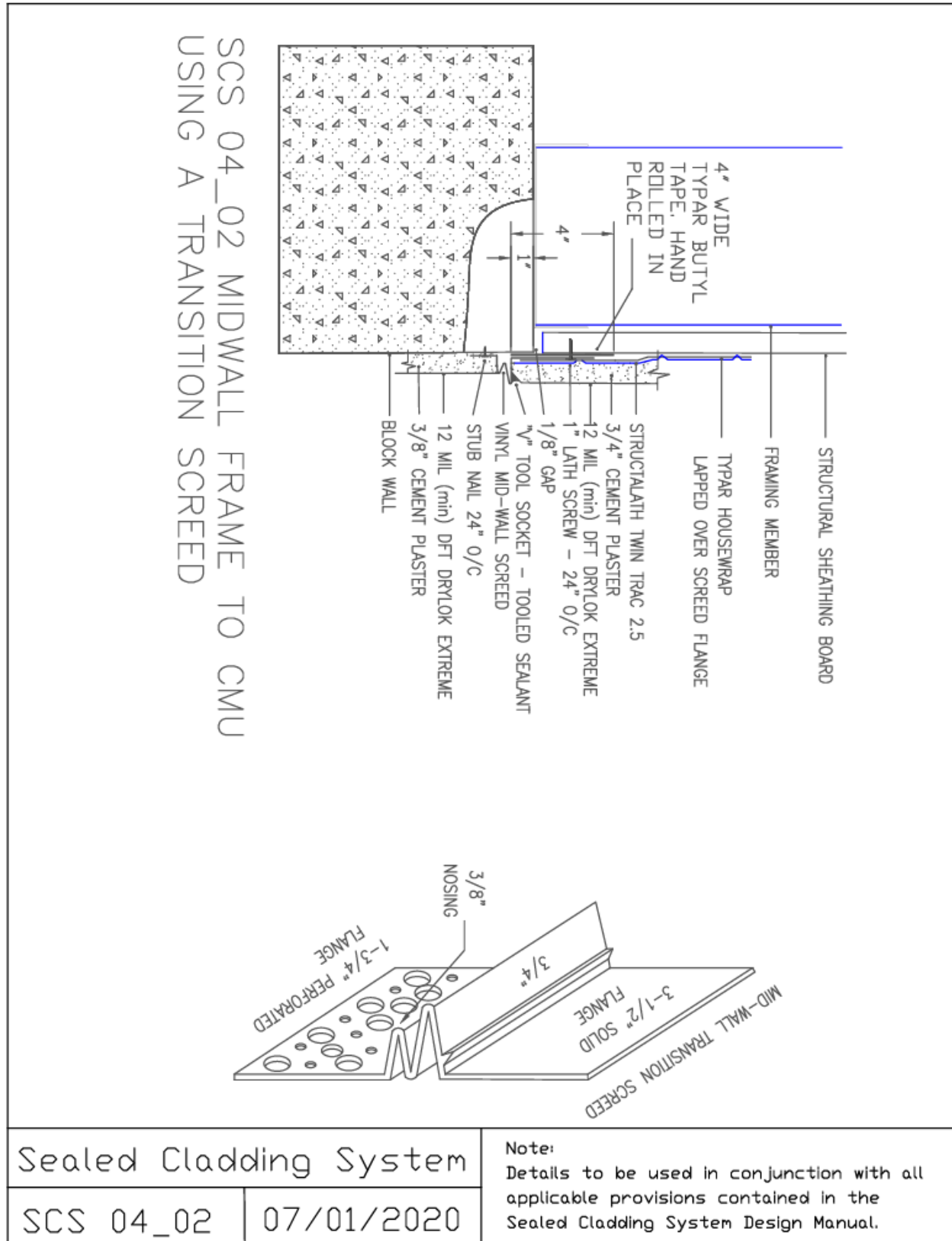

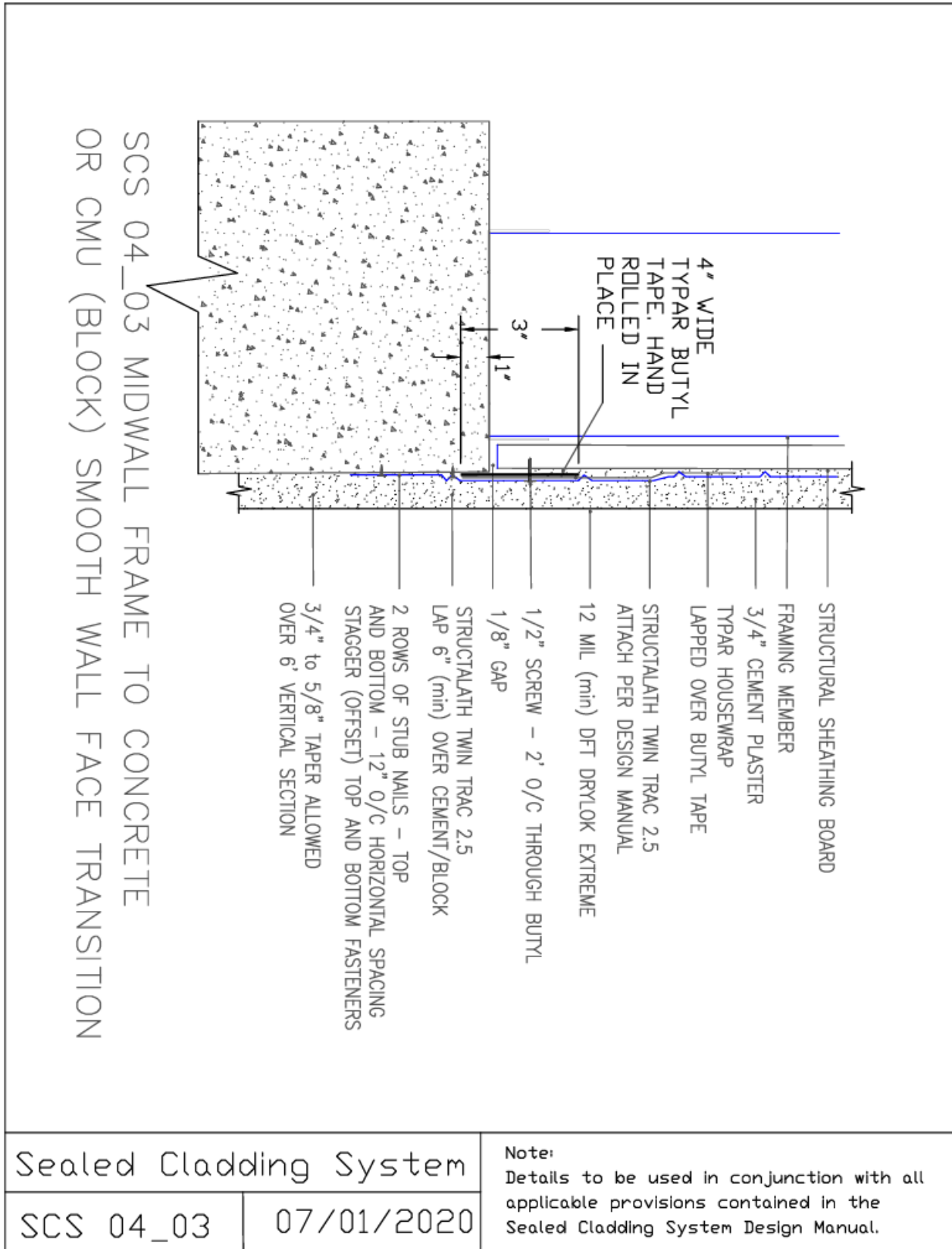



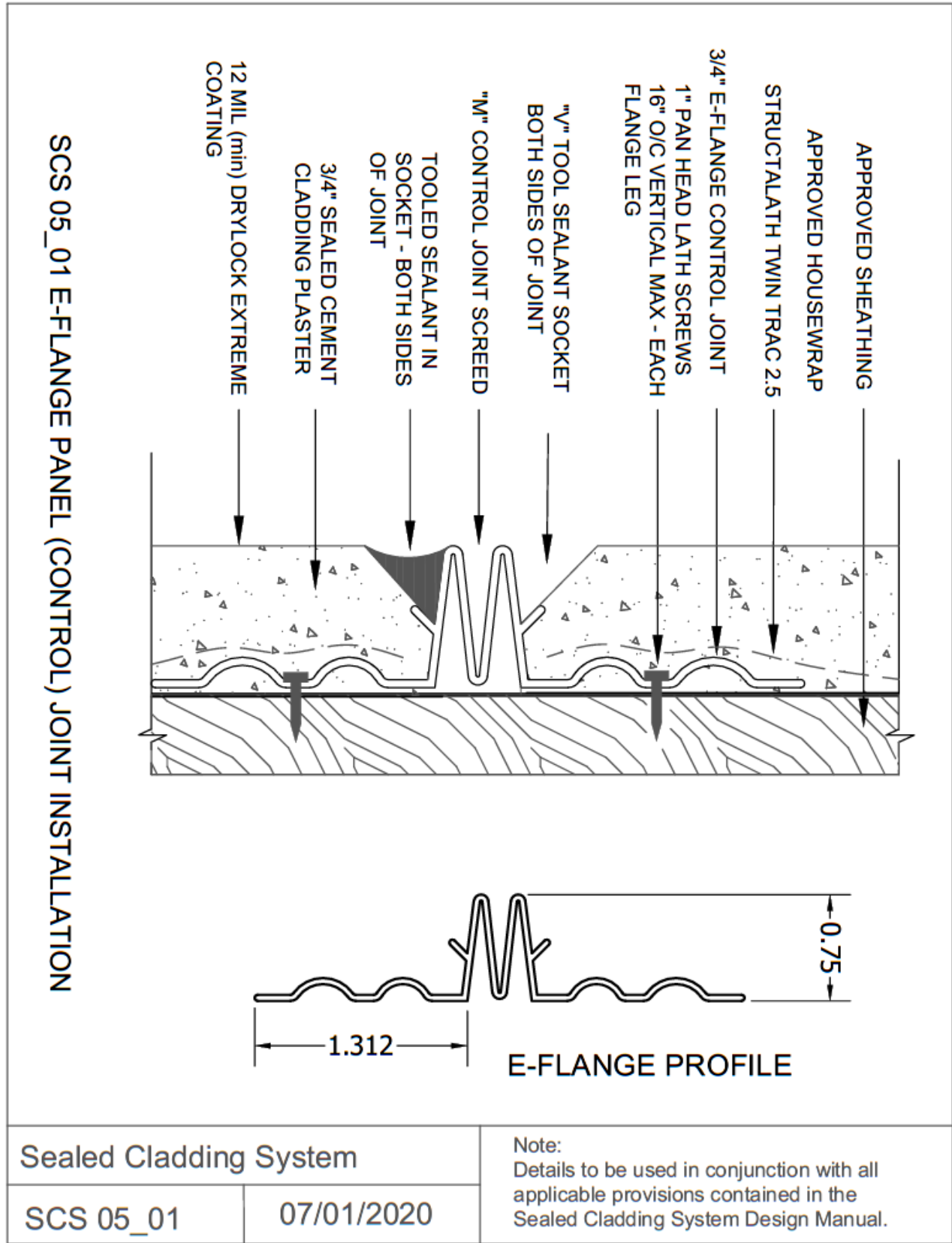

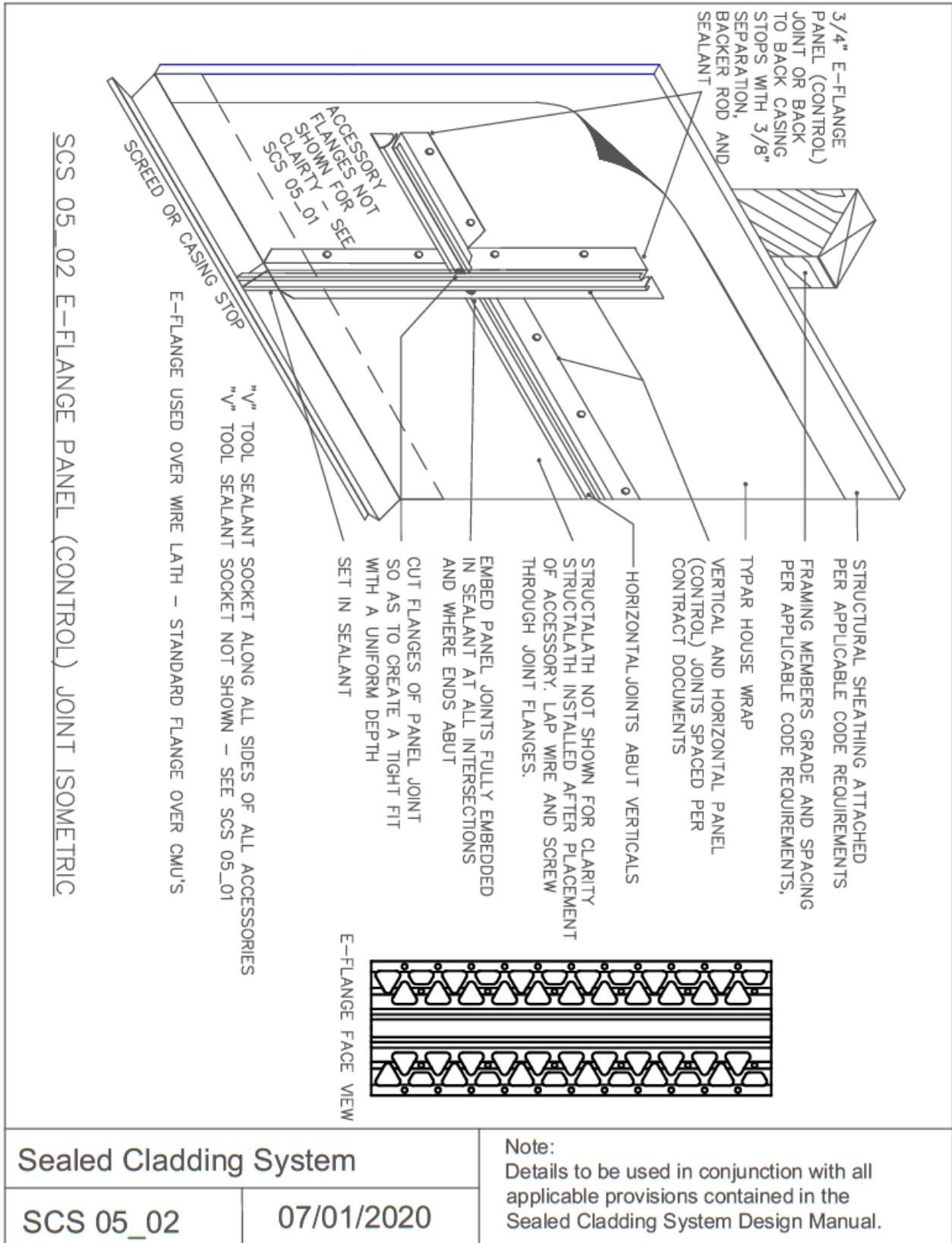

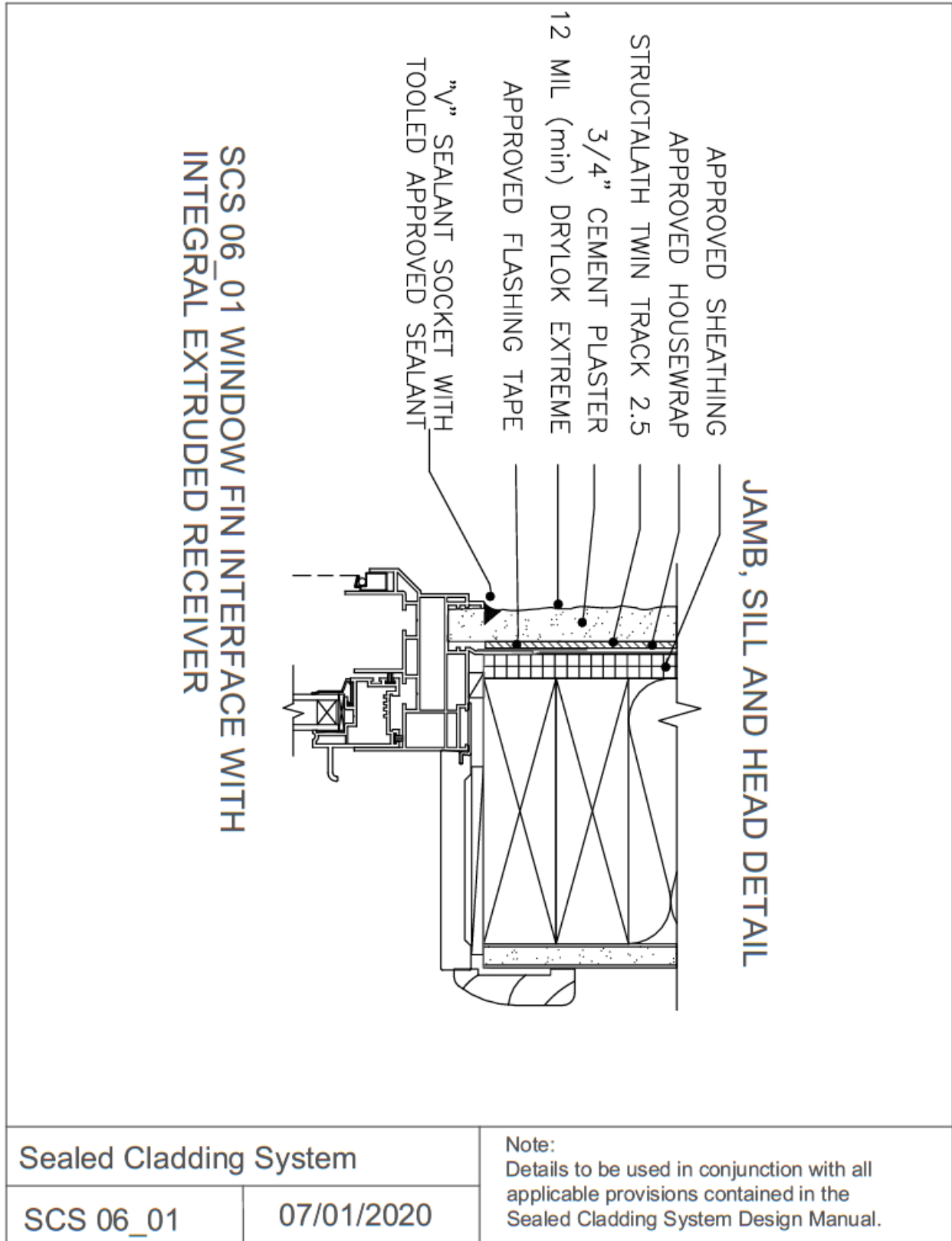

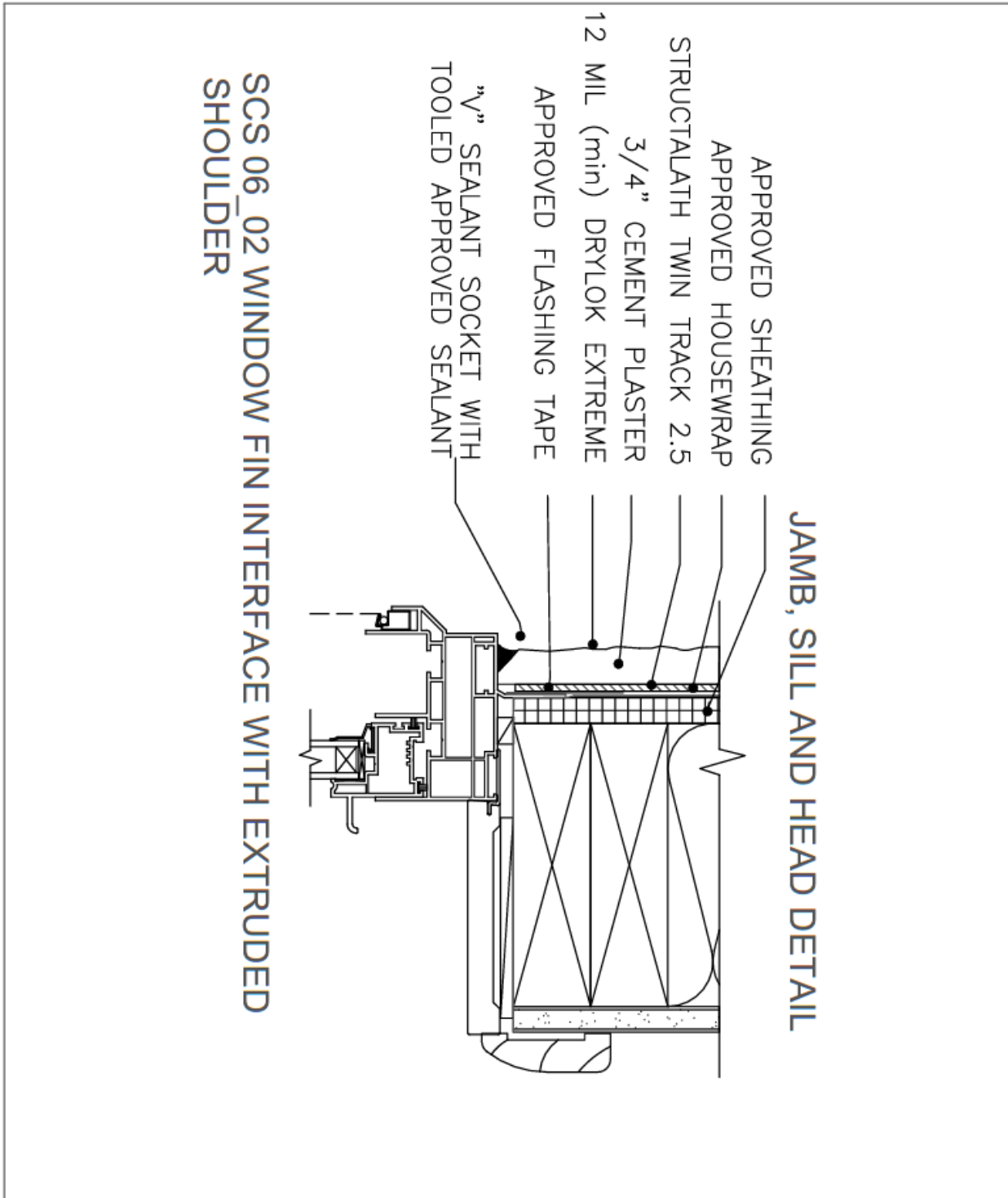

Sealed Cladding System		Note: Details to be used in conjunction with all applicable provisions contained in the Sealed Cladding System Design Manual.
SCS 06_02	07/01/2020	



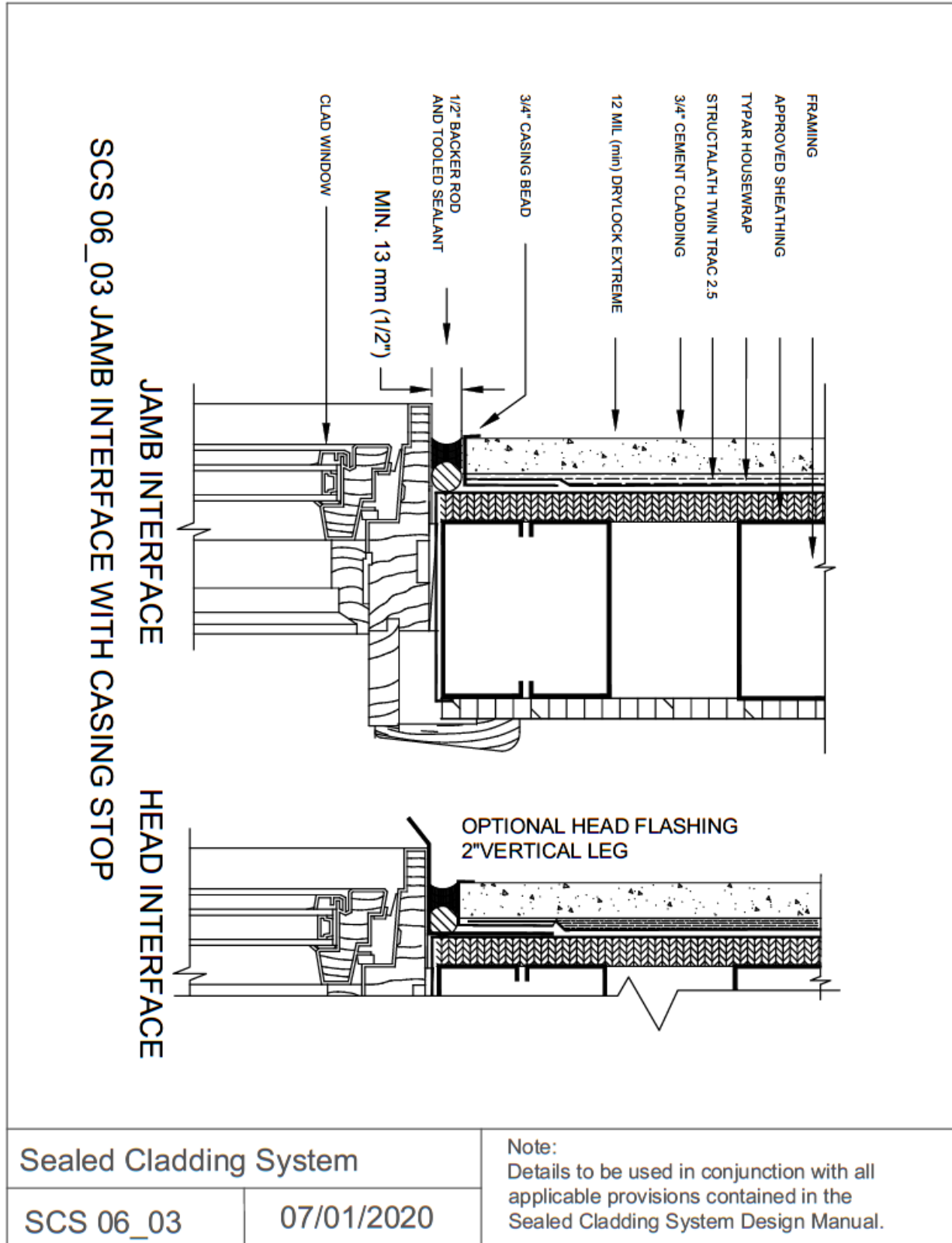

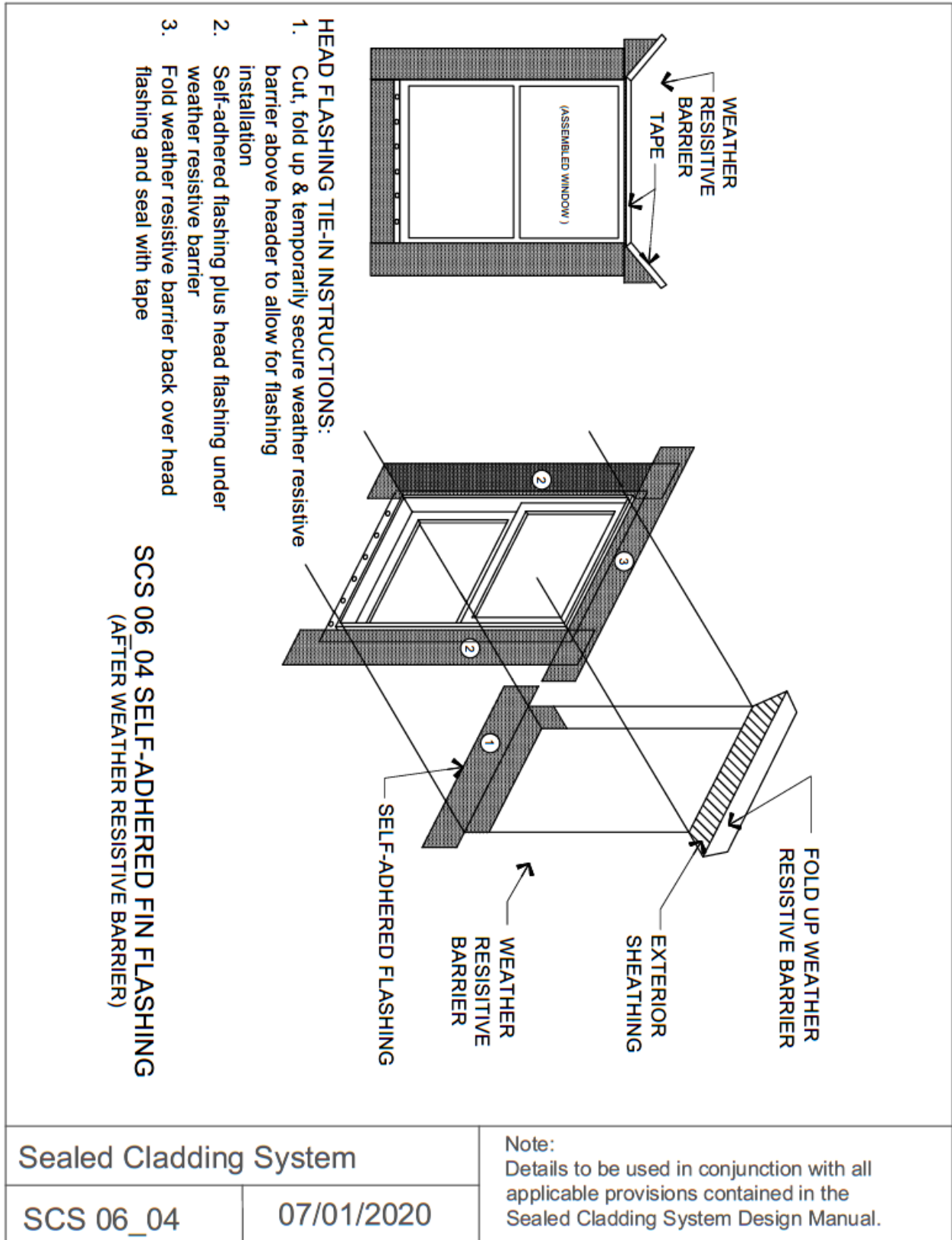

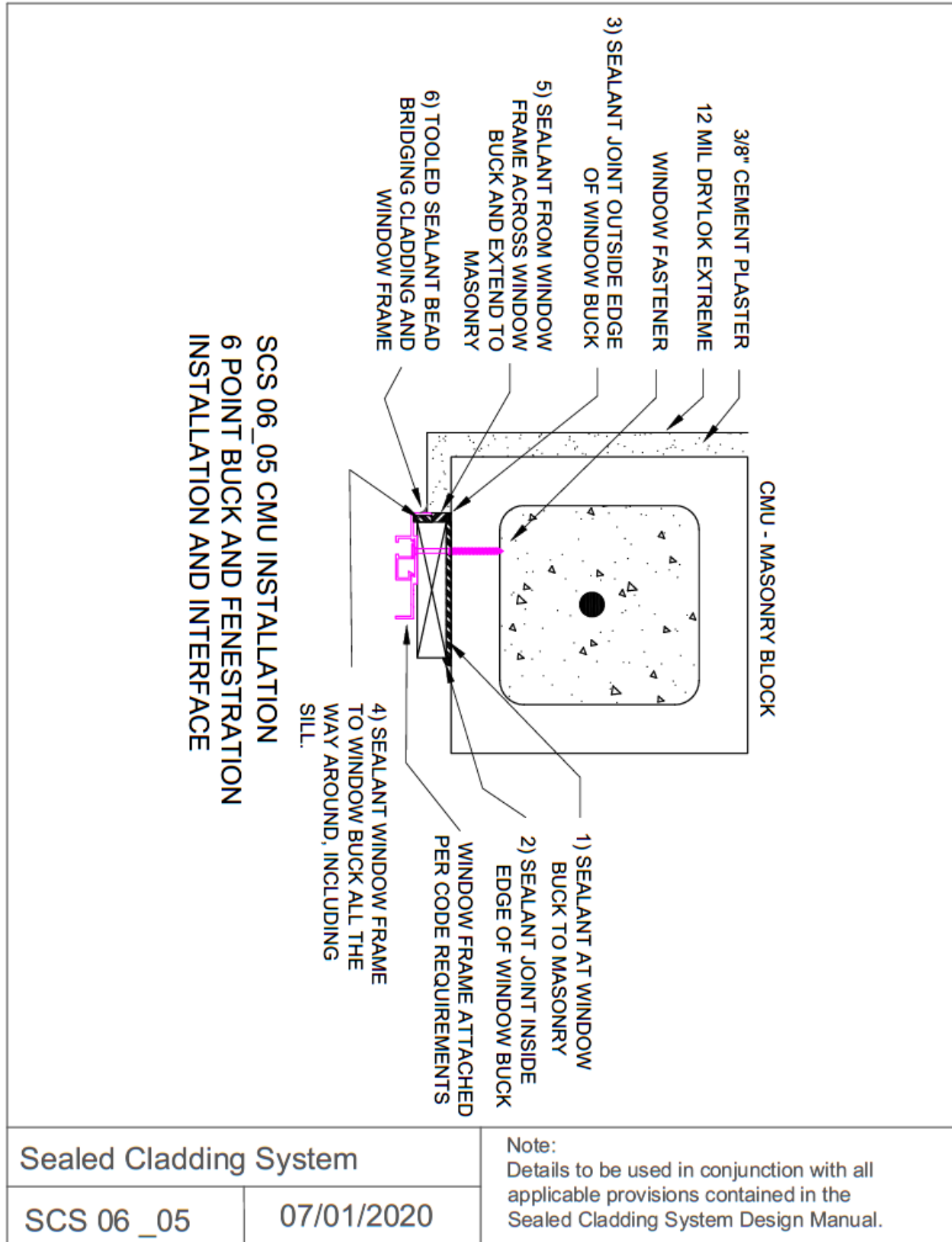

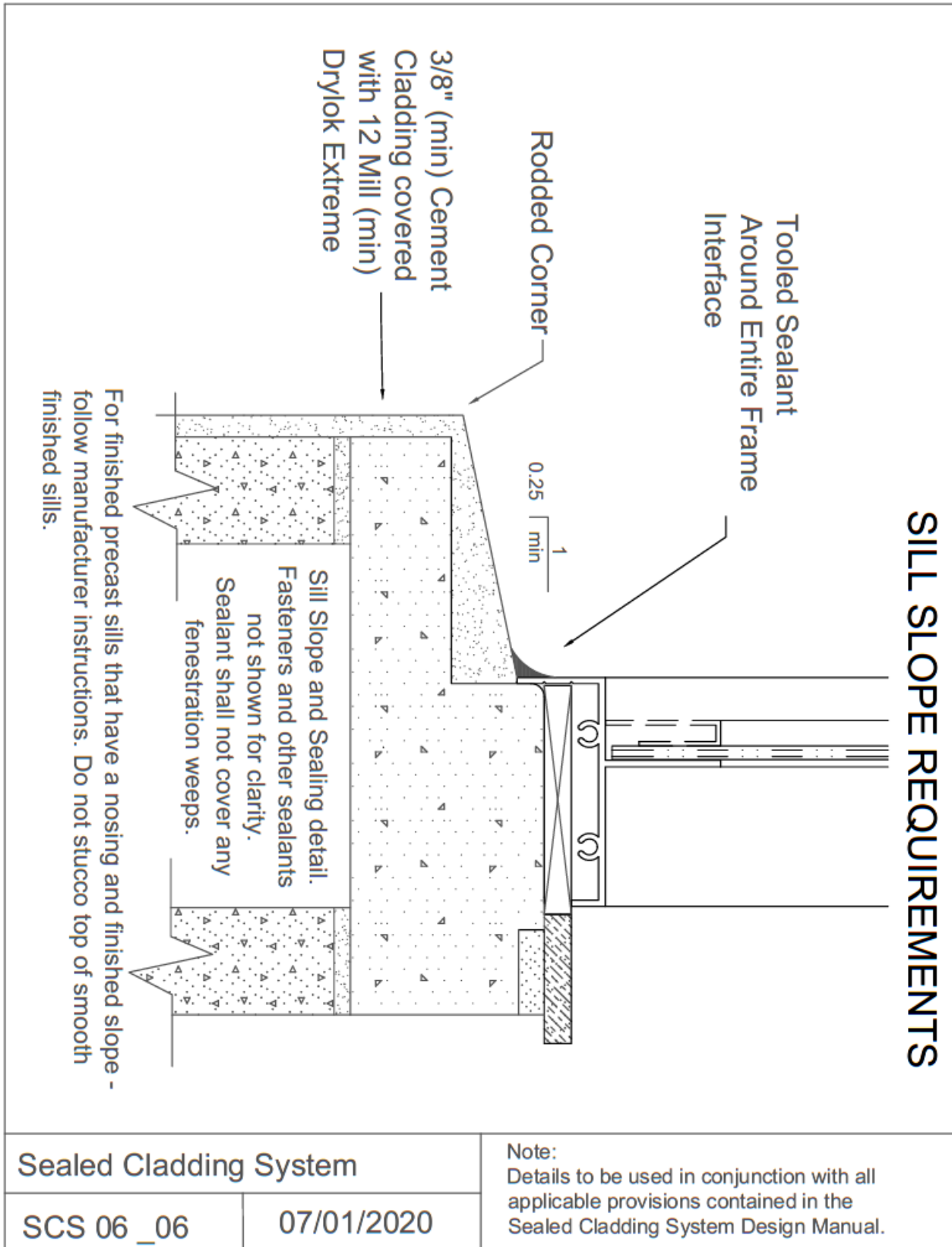



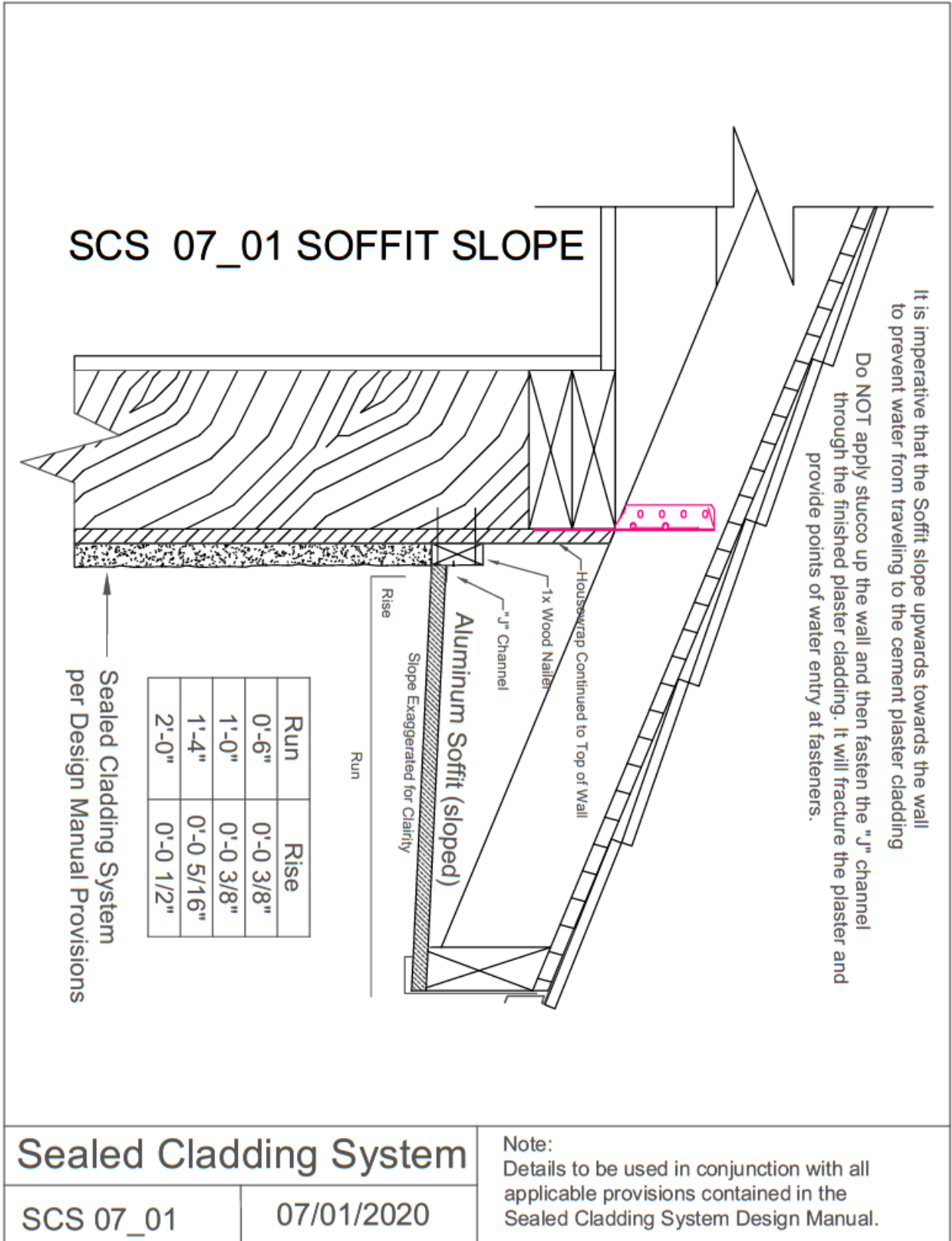

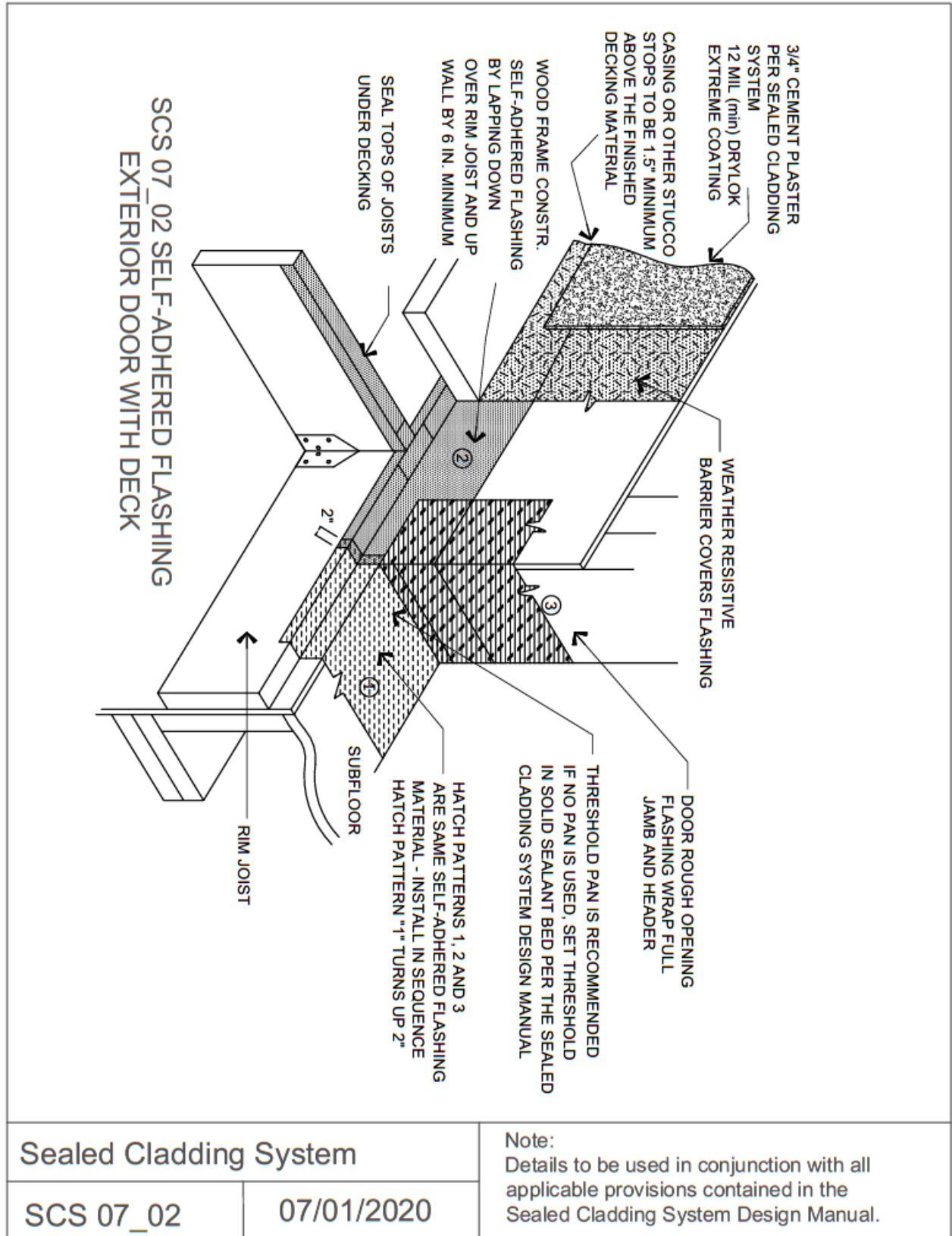

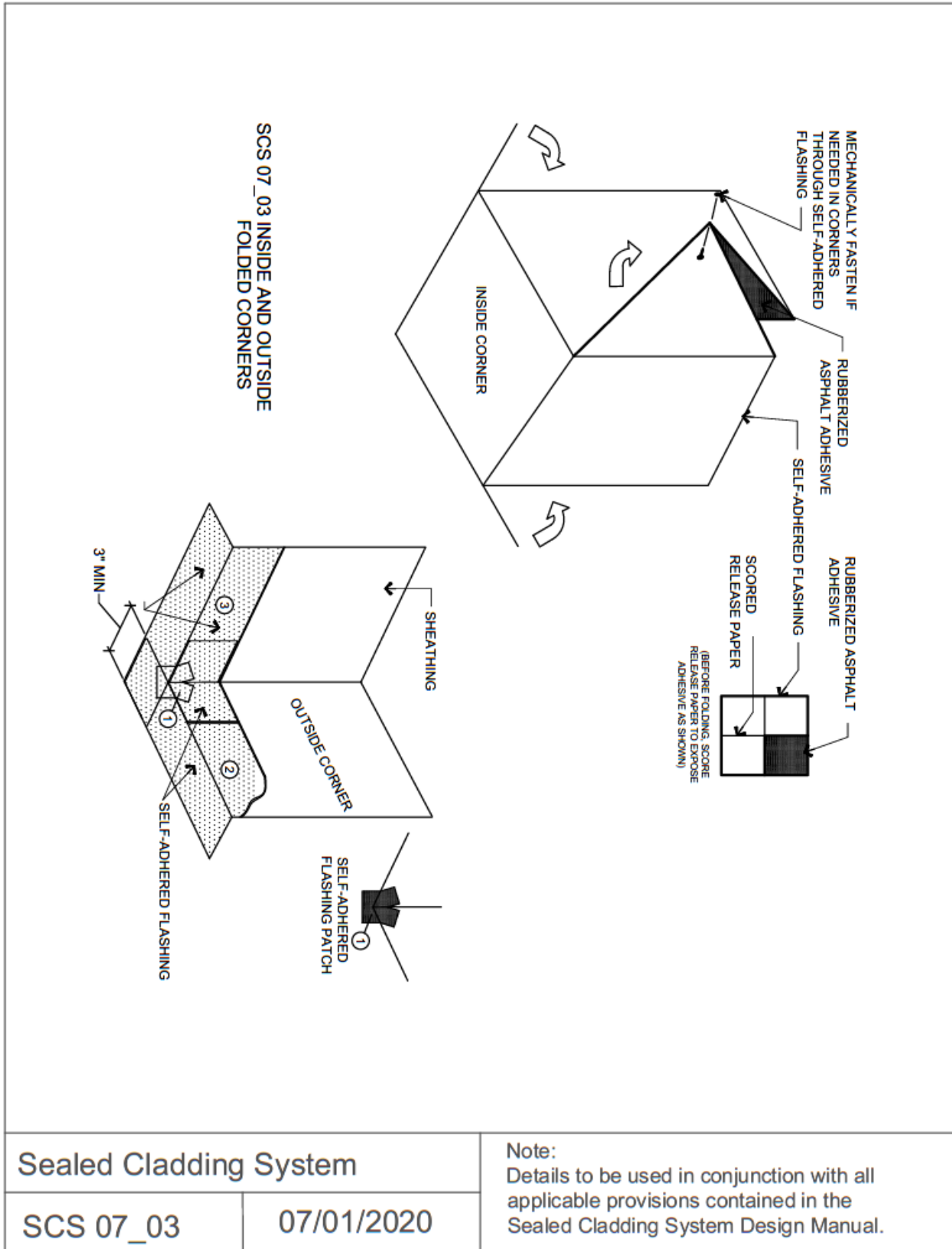

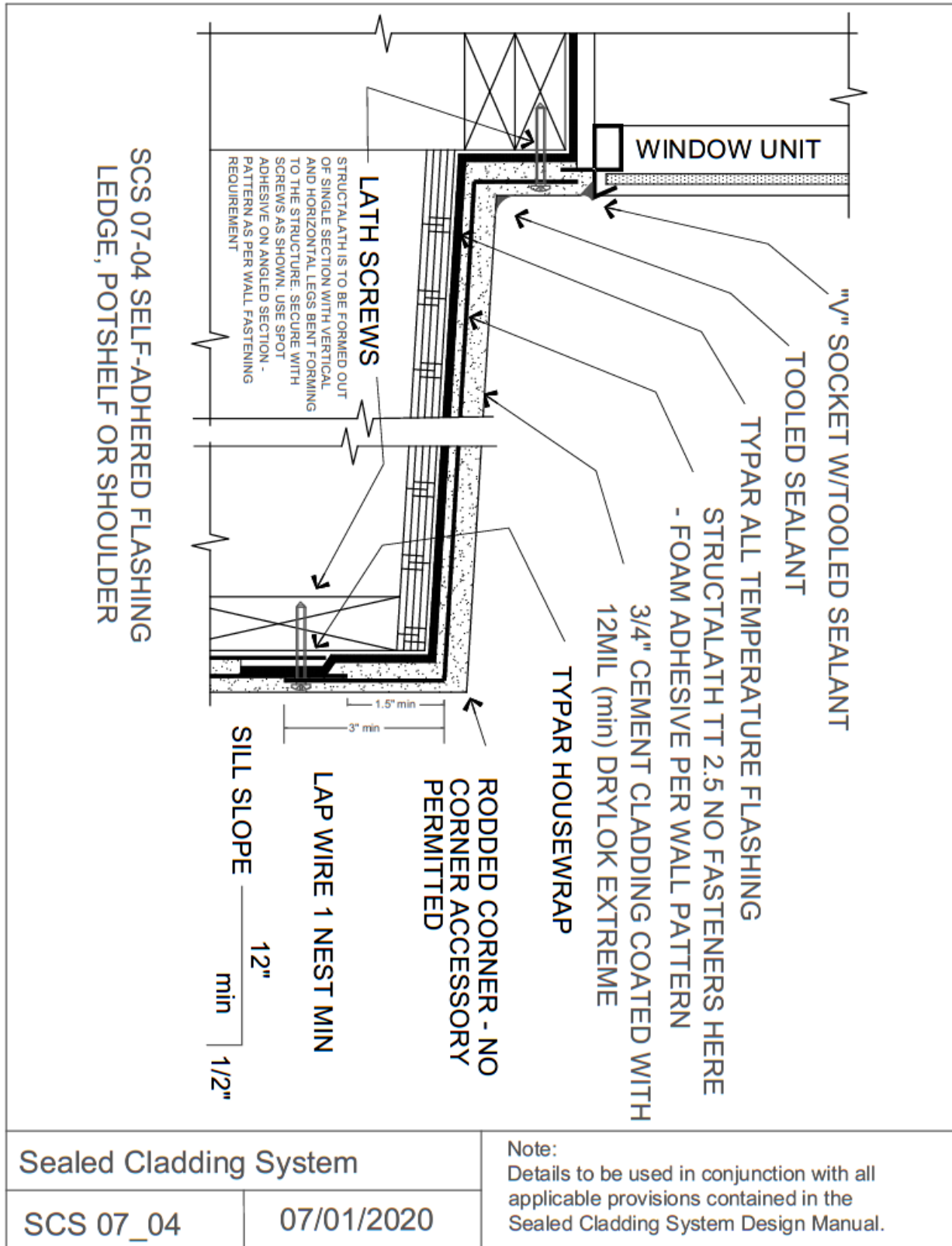



## **CHAPTER 12**

### **MANUFACTURERS INSTRUCTIONS**

The following pages represent current information regarding the products used in the Sealed Cladding System. Please visit each material suppliers website for specific or expanded information if necessary.

[Typar.com](http://Typar.com)

[Structawire.com](http://Structawire.com)

[UGL.com](http://UGL.com)

Also remember to stay current with the articles and publications at [theStuccoInstitute.com](http://theStuccoInstitute.com)

Special Note. The Sealed Cladding System rejects water at its outer face and is approved without a "bond breaker" or any additional layer of felt or house wrap. Additional Layers may be used but are not necessary. Install Typar over the sheathing and the lath and cement cladding over the Typar.

# TYPAR® WEATHER PROTECTION SYSTEM INSTALLATION GUIDE

## TABLE OF CONTENTS

Table of Contents .....	01
Special Installation Considerations .....	01
Code Requirements .....	02
Approvals and Reports .....	02
Recommended Materials .....	02
Product Size Data .....	02
Vertical Wall Installation .....	03
Tilt Wall Installation .....	04
Window and Door Preparation .....	05
Window Flashing General Instructions .....	06
Typical Window Flashing .....	07
Flashing Arched Windows .....	08
Flashing Penetrations .....	09

These instructions describe how to install the TYPAR Weather Protection System for exceptional exterior water management. For more detail on other TYPAR® products, please visit [www.TYPAR.com](http://www.TYPAR.com)

## SPECIAL INSTALLATION CONSIDERATIONS

### Stucco\*\*

When stucco is installed over wood-based sheathing, the 2006-IBC (section 2510.6) and the 2006 IRC (section R703.6.3) require "a water-resistive barrier with a performance at least equivalent to two layers of Grade D paper" or a layer of water-resistive barrier (WRB) which is separated from the stucco by an "intervening layer." When TYPAR® WRB is used behind stucco, it should be separated from the stucco by a second layer of TYPAR WRB, a layer of Grade D building paper, or the Grade D paper backing of paper-backed lath.

### Brick\*\*

The 2006 IRC (section R703.7.4.2) requires a min. 1" (25 mm) airspace separating the brick from the WRB. The Brick Industry Association recommends a 1" (25 mm) airspace in front of the wood stud construction and a 2" airspace in front of a steel stud construction.

### Stone Veneer\*\*

The 2006 IBC (Section 1405.6) requires two layers of WRB behind stone. Over wood frame construction, TYPAR WRB should be installed behind stone the same way it is installed behind stucco.

### Wood Siding\*\*

TYPAR WRB and wood siding must be installed according to the manufacturer's instructions and the industry standards. Wood industry associations recommend siding should be primed before installation.

\*\*TYPAR® recommends that the installation of any material must first follow the local applicable building codes.



**TYPAR® WEATHER PROTECTION SYSTEM - INSTALLATION GUIDE**

02

**CODE REQUIREMENTS**

The 2006 International Building Code (IBC) and the 2006 International Residential Code (IRC) require a water-resistive barrier equivalent to ASTM D226 Type 1#15 felt be installed behind the exterior cladding. TYPAR® BuildingWrap exceeds these standards.

**APPROVALS AND REPORTS**

ICC-ESR-1404

CCMC #12892-R & 12884-R

TYPAR BuildingWrap meets AC38 standards, Acceptance Criteria for Water-Resistive Barriers.

TYPAR® flashing products meet the requirements for AAMA 711.

**RECOMMENDED MATERIALS**

TYPAR BuildingWrap

TYPAR® All-Temperature Flashing

TYPAR® Butyl Flashing

TYPAR® Flexible Flashing

TYPAR® Construction Tape

**PRODUCT SIZE DATA**

<b>Weather-Resistive Barriers</b>	<b>Size</b>	<b>Rolls/Pallet</b>
TYPAR BuildingWrap	3' x 100'	144
	40' x 100'	144
	4'5" x 200'	32
	9' x 100'	40
	9' x 150'	36
	9' x 195'	32
	9'6" x 95'	40
	10' x 100'	40
	10' x 150'	36
	10' x 195'	32
<b>Accessories</b>	<b>Size</b>	<b>Rolls/Case</b>
TYPAR All-Temperature Flashing	4' x 75'	12
	6' x 75'	8
	9' x 75'	4
	12' x 75'	3
TYPAR Butyl Flashing	4' x 75'	9
	6' x 75'	6
	9' x 75'	4
	12' x 75'	3
TYPAR Flexible Flashing	6' x 75'	3
	9' x 75'	2
TYPAR Construction Tape	1-7/8" x 165'	24
	3" x 165'	16
TYPAR Construction Tape Canada	60 mm x 55 m	24



**TYPAR® WEATHER PROTECTION SYSTEM - INSTALLATION GUIDE**

03

**VERTICAL WALL INSTALLATION**

Install TYPAR® BuildingWrap over an approved exterior sheathing after the framing is complete and before the windows and doors have been installed. Plastic-capped fasteners should be used and spaced at 32" OC (vertically and horizontally) when being applied over 7/16" OSB or 15/32" plywood. When installing over metal framing, use screws with washers. If the windows and doors have already been installed, trim the TYPAR® WRB close to the window frame and flash according to the TYPAR® flashing instructions.

**STEP 1**

Start at the bottom of one end of the wall with the printed side facing out. When starting at a corner, overlap by a minimum of 12".

Place the housewrap roll horizontally and roll out the first course evenly, covering rough window and door openings. A minimum of a 1" (25.4 mm) overlap on the sill plate is required; however, for maximum protection, a 2-4" (51-102 mm) overlap on the sill plate is recommended.

Pull the TYPAR WRB snug and avoid wrinkles and creases. Ensure that the product is level.

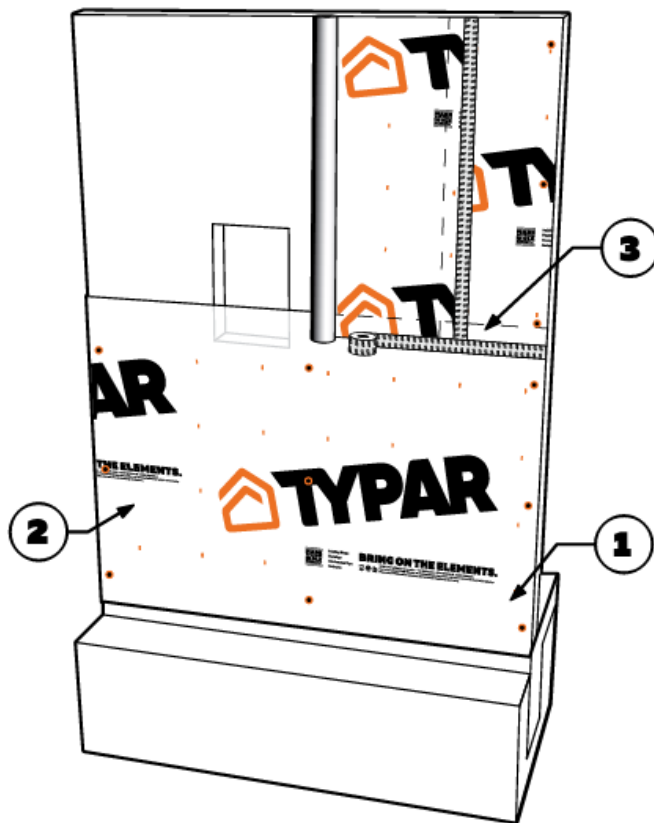
**STEP 2**

Fasten the TYPAR WRB to the stud using plastic-capped nails or plastic-capped staples at 32" OC, both horizontally and vertically.

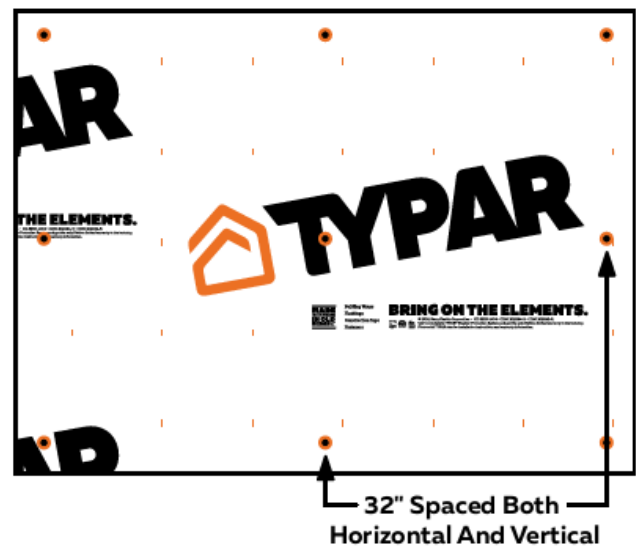
**STEP 3**

The upper layer of TYPAR WRB should overlap the bottom layer by a minimum of 6" (152 mm) vertically and horizontally. Ensure proper shingling throughout the installation to properly shed water. Once the structure is completely covered, tape all seams and penetrations using TYPAR® Construction Tape. (Please refer to the TYPAR flashing instructions for more detailed instruction on penetrations and window flashing installation.)

**STEP 4**

After the installation is complete, and before the exterior cladding is installed, inspect the TYPAR WRB for tears. Repair the issues with TYPAR Construction Tape or TYPAR flashing.



**TYPAR® WEATHER PROTECTION SYSTEM - INSTALLATION GUIDE**

04

**TILT WALL INSTALLATION**

Install TYPAR® BuildingWrap over an approved exterior sheathing after the framing is complete and before the windows and doors have been installed. Plastic-capped fasteners should be used and spaced at 32" OC (vertically and horizontally) when being applied over 7/16" OSB or 15/32" plywood. When installing over metal framing, use screws with washers.

**STEP 1**

Begin with the wall lying on the ground. Start at one corner, allowing an extra 12" (304 mm) flap for the corner and align the guide marks on the TYPAR® WRB with the studs. Ensure a 6" excess flap on one side to allow for overlap to the next wall section. Fasten TYPAR® to the wall at 32" both horizontally and vertically.

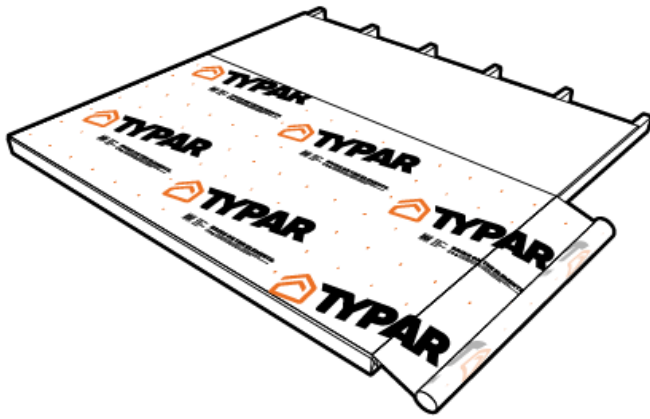
**STEP 2**

When starting a new section, fold the beginning side flap over the vertical stud and secure (only one side). After fastened, trim the excess TYPAR WRB. Remember to allow enough so that the bottom excess overlaps the sill plate when the wall is put into place. As each wall is put into place, ensure that each side flap is on the exterior of the building.

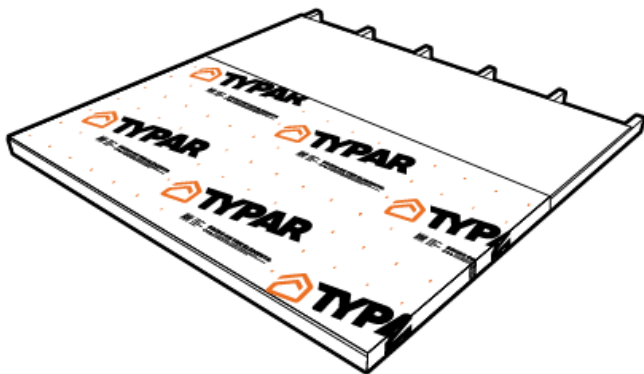
**STEP 3**

Secure the side flaps and the bottom flap using plastic-capped nails or plastic-capped staples, TYPAR® Construction Tape, and/or a non-silicone caulk.

**STEP 4**

The second course of TYPAR should overlap the bottom sheet at least 6" (152mm). Both vertical and horizontal seams ensure proper drainage by using the shingling method.

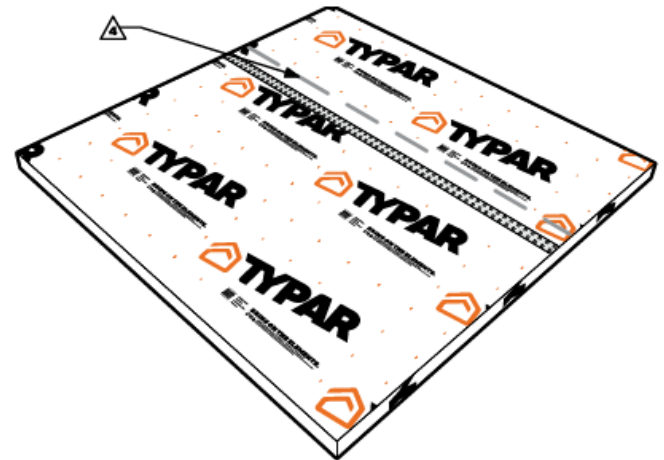
**STEP 5**

Tape all seams with TYPAR Construction Tape. (Please refer to the TYPAR flashing instructions for further detail.)

**STEP 6**

After the installation is complete, and before the exterior cladding is installed, inspect the TYPAR WRB for tears. If issues are found, tape the imperfections with TYPAR Construction Tape or TYPAR flashing.

**TYPAR® WEATHER PROTECTION SYSTEM - INSTALLATION GUIDE**

05

**WINDOW AND DOOR PREPARATION****Preparing for Window Installation****STEP 1**

After wrapping the structure and covering all rough openings, cut a horizontal line across the top of the window opening. The cut should not extend past the rough opening.

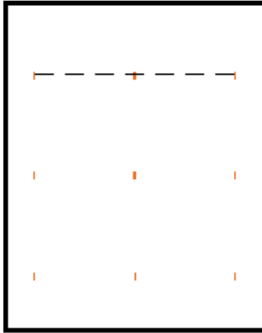
**STEP 2**

Start at the top center and make a vertical cut running two-thirds of the way down the opening.

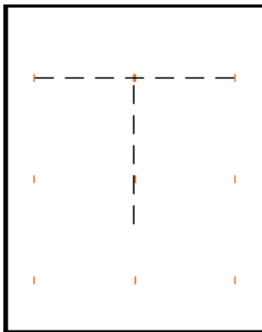
**STEP 3**

From that stopping point, cut diagonally to both lower left and right corners of the opening.

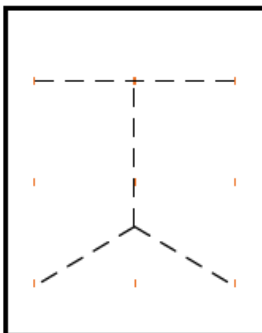
**STEP 4**

Pull each of the flaps tightly inside the rough opening and attach them to the frame with nails, staples or tape.

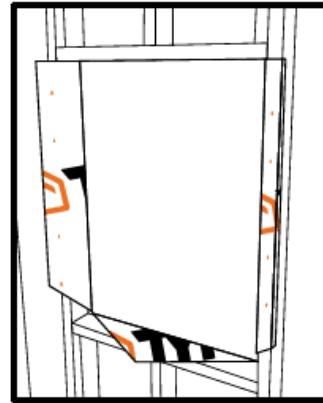
**STEP 5**

At the window header, make a 6" diagonal cut at a 45-degree angle on both corners. Fold the material up exposing the sheathing. Now install the window or door according to the manufacturer's instructions. The final step is to flash all seams and flanges securely (refer to TYPAR® flashing instructions). TYPAR flashing should also be installed in accordance with window manufacturer's instructions and according to the ASTM 2112 standard.

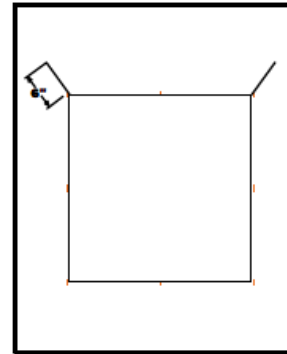

**TYPAR® WEATHER PROTECTION SYSTEM - INSTALLATION GUIDE**

06

**WINDOW FLASHING GENERAL INSTRUCTIONS**

Installation methods approved by the American Architectural Manufacturers Association (AAMA) are acceptable for TYPAR® products and system warranties.

Flashing products should always be installed on a dry surface that is free of dirt and debris. Wipe surfaces to remove moisture, grease, and other contaminants that could interfere with adhesion.

Avoid placing fasteners where the TYPAR flashing will be installed; however, the fasteners can be installed over the flashing.

Most circumstances do not require you to prime the surface before installing TYPAR flashing. However, some adverse weather conditions, extreme temperatures, or specialty installations, such as concrete, masonry, or fiber-face gypsum board may require a primer to obtain optimal adhesion. Install the primer according to the manufacturer's installation instructions.

The use of a heat gun will assist in adhesion during colder conditions.

Do not expose the flashing to direct sunlight for longer than recommended by the manufacturer.

Do not apply the flashing to a flexible vinyl surface, although rigid PVC is acceptable. Please check with the window manufacturer for compliance with rubberized asphalt flashing products.

For more information, visit our website at [www.TYPAR.com](http://www.TYPAR.com) or contact your local TYPAR sales rep.

**Tools Needed**

Brush for surface preparation

Utility knife or scissors

Gloves

J-roller

Primer (optional)

**TYPICAL WINDOW FLASHING****STEP 1**

Install the window sill pan according to the manufacturer's instructions. Alternatively, you can create a sill pan using TYPAR® Flexible Flashing. Cut a piece that is 12" longer than the length of the rough opening window sill.

Carefully peel off the release liner. Center the flashing in the center of the rough opening and work your way toward the corners and then up the sides. Note: the Flexible Flashing should overlap to the outside of the wall by 2-3". Only stretch the flashing in the corners.

Alternatively to above, you can create a sill pan by installing TYPAR® straight flashing along the bottom sill and installing TYPAR Flexible Flashing on the corners only.

If needed, secure the fanned edges of the TYPAR Flexible Flashing with a plastic-capped nail or plastic-capped staple.

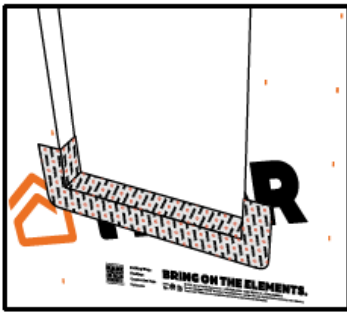
**STEP 2**

Apply a continuous bead of sealant to the back of the window or on the wall. Do not apply the sealant across the bottom of the sill or on the bottom of the window. This area is left open to allow for proper drainage.

Install the window according to the manufacturer's installation instructions.

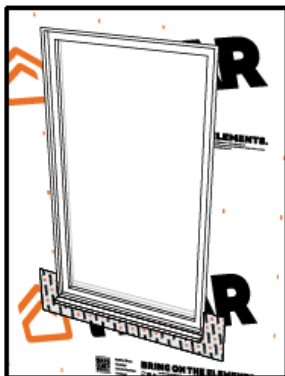
**STEP 3**

Cut two pieces of TYPAR flashing long enough to extend 1" above the window head flange and 1" below the window sill flange. Carefully peel off the release liner and apply the flashing on both sides of the window. Make sure to cover the entire window flange, and press firmly either by hand or using a J-roller. Ensure there are no wrinkles or bubbles.

Cut a piece of TYPAR flashing for the head flashing. Ensure that the piece is long enough to extend by 1" on both sides of the jamb flashing. Remove the release liner and carefully install the flashing. Cover the window flange and press firmly by hand or using a J-roller.

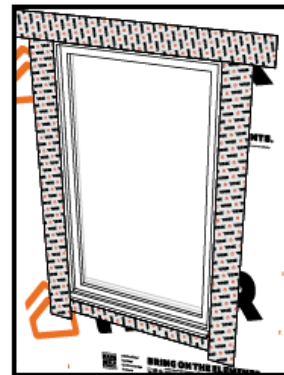
**STEP 4**

Release the upper flap of the TYPAR® WRB that you cut earlier. Tape the 45-degree cuts using TYPAR® Construction Tape or TYPAR flashing. DO NOT tape the WRB along the top of the window flange.

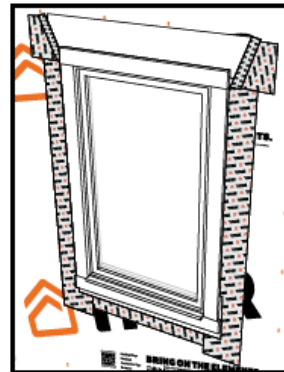

**TYPAR® WEATHER PROTECTION SYSTEM - INSTALLATION GUIDE**

08

**FLASHING ARCHED WINDOWS****STEP 1**

Start with the TYPAR® Flexible Flashing. Cut a piece that is 12" longer than the length of the rough opening window sill.

Carefully pull off the release liner. Center the flashing in the center of the rough opening and work your way toward the corners and then up the sides. Note: the Flexible Flashing should overlap to the outside of the wall by 2-3". Only stretch the flashing in the corners.

Alternatively to above, you can create a sill pan by installing TYPAR® straight flashing along the bottom sill and installing TYPAR Flexible Flashing on the corners only.

If needed, secure the fanned edges of the TYPAR Flexible Flashing with a plastic-capped nail or plastic-capped staple.

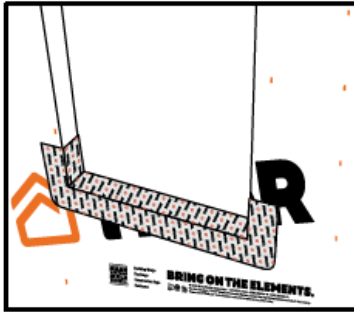
**STEP 2**

Apply a continuous bead of sealant to the back of the window or on the wall. Do not apply the sealant across the bottom of the sill or on the bottom of the window. This area is left open to allow for proper drainage.

Install the window according to the manufacturer's installation instructions.

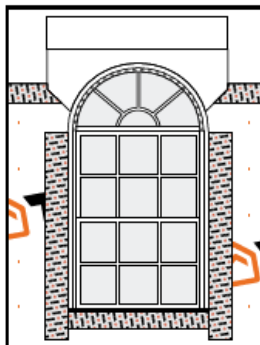
**STEP 3**

Cut two pieces of TYPAR flashing long enough to extend 1" above the window head flange and 1" below the window sill flange. Carefully peel off the release liner and apply the flashing on both sides of the window. Make sure to cover the entire window mounting flange, and press firmly either by hand or using a J-roller. Ensure there are no wrinkles or bubbles.

For the head flashing, cut a piece of TYPAR Flexible Flashing 12" longer than the length on the window arc. Carefully begin to peel off the release liner and install the flashing to the contour of the window flange as you go. The head flashing should overlap the jamb flashing by at least 6". If needed, use button fasteners to secure the outer edges.

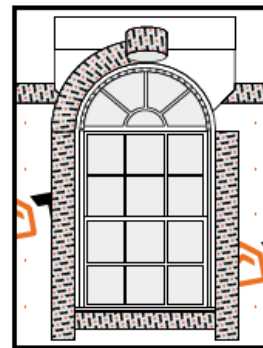
**STEP 4**

Flip down the WRB that you cut earlier. Trim the WRB tight to the window arc if needed. Tape the seams using TYPAR® Construction Tape. DO NOT tape along the window arc.

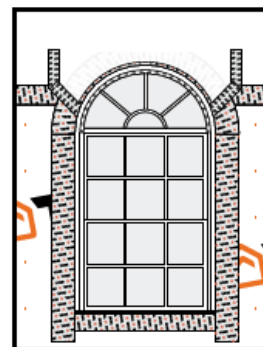



**TYPAR® WEATHER PROTECTION SYSTEM - INSTALLATION GUIDE**

09

**FLASHING PENETRATIONS**

Penetrations such as exhaust fans, exterior electrical outlets, dryer vents, exterior lights, and gas outlets are a common entrance for bulk water into the wall cavity. Using TYPAR® flashing will ensure proper water holdout and maintain the integrity of the structure.

The method is similar to flashing a window. Start by flashing the bottom of the penetration. Ensure to shingle the upper tape over the bottom tape.

Some penetrations have flanges, such as dryer vents. These penetrations should be flashed according to the details below.

**STEP 1**

Install the vent according to the manufacturer's recommendations. Trim the housewrap as close as possible around the perimeter of the vent.

**STEP 2**

Flash the vent using the same method as windows. Starting at the bottom flange, cut the flashing so that it extends past the flanges by 1" on both sides. Now apply the flashing to the sides of the vent. Remember to extend the flashing 1" on both top and bottom. Make sure to smooth out wrinkles and air bubbles. The use of a J-roller is optional.

**STEP 3**

The final step is to install the flashing across the top. Extend the flashing out at least 1" on both sides.

Note: This type of installation is suitable for several different penetrations. Always use the shingling method and ensure a tight seal around the flange/penetration.

1.

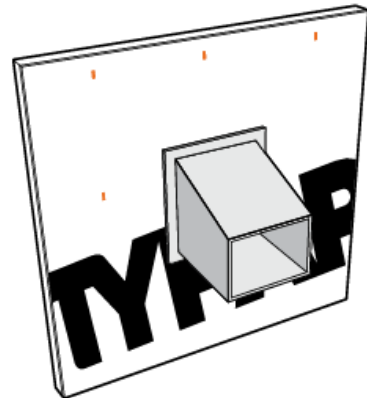

2.

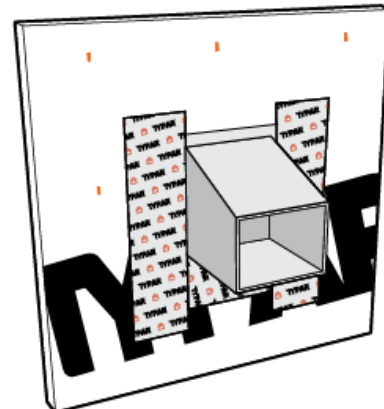

3.

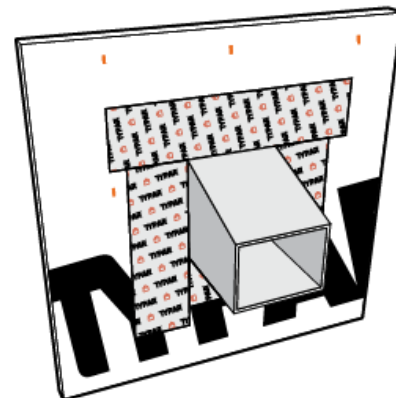

TYPAR® BuildingWrap is part of a complete Weather Protection System, which also includes TYPAR® MetroWrap®, TYPAR® Flashings and Construction Tape.

For more information, visit [www.TYPAR.com](http://www.TYPAR.com)

The fastening pattern shown is for areas with wind pressures less than 30 psf. Follow the attachments requirements contained in Chapter 5 of this manual.



## TWINTRAC INSTALLATION GUIDE

Manufactured by Structa Wire Corp. IAPMO UES 2017; US PATS 6305432, 7287356

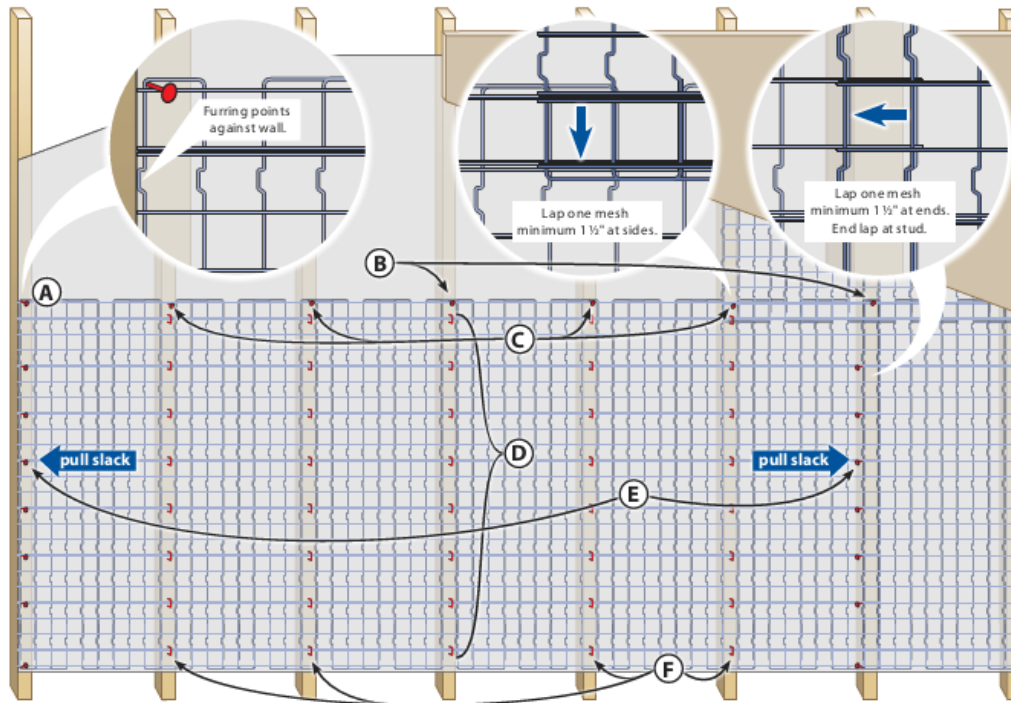

### Installation of Structalath Twin Trac

- Determine starting point and plan comfortable working length for each lath section.
- The lath can be unrolled on the ground and pre-cut, or the lath can be unrolled against the wall and then cut.
- If unrolled on the ground, minimize any undue distortions or stepping on the lath.
- Also ensure when installing that furring points are oriented against the wall.
- Position the starting end of the lath at the appropriate height.
- Drive a roofing nail into one of the starting ears, against a vertical wire. See **(A)** on illustration.
- Unroll the lath or place lath on the wall.
- Every 6-8 feet drive another roofing nail loosely to position the mesh at the right height. This nail should be between vertical wires. See **(B)** on illustration.
- Continue to end of desired lath section.
- Cut the lath.
- Pull any slack from the lath and nail the top loosely. See **(C)** on illustration.
- Go to mid point of the lath section and fasten the lath vertically every 6 inches or at every pair of twin trac wires. See **(D)** on illustration.
- Then go to either end of the lath section, pull the lath tight either by hand, or by driving nails at an angle and nail off vertically. See **(E)** on illustration.
- Once lath is tightened at each end, then fastening can be completed at each stud location. See **(F)** on illustration.
- Proceed to next course of lath following steps of 1 to 14.

### Lapping

- Side laps – Structalath Twin Trac is to be lapped one mesh width, this is approximately 1½ inches.
- End laps are approximately 1½ inches. This lap must occur over a framing member.

### Fastening

Structalath Twin Trac may be fastened:

- On the furring point located on the vertical wire, or
- At the intersection of the vertical and horizontal wires, or
- At any point along the horizontal wire, or
- At any point between the parallel wires. If staples are used, then the staples could capture both parallel wires.
- Fasteners should be positioned at framing members

Fastener locations for Structalath Twin Trac should coincide with locations of Twin Tracs.

Fastener types and sizes must be in accordance with ASTM 1063 or in accordance with local building codes or in accordance with engineering drawings and specifications for the project.

If staples are being utilized, they should be oriented parallel to the framing member to minimize risk of missing the framing, and puncturing the WRB.

For additional information, call  
1-800-887-4708 or visit [www.structawire.com](http://www.structawire.com)

*Note: Structa Wire has prepared these instructions as a guideline for installers – alternate installation methods may be used.*

# TWIN TRAC 2.5

## Specification Sheet

IAPMO UES 2017 US Patent # 6,305,424, B1 7,287,356, B2 • CSI 09 22-36



STRUCTALATH **TWIN TRAC 2.5** is a self furring welded wire lath for use as an alternative to the 2.5 lb/yd<sup>2</sup> diamond mesh metal lath specified in ASTM C 847 and for use as an alternative to the 1.14 lb/yd<sup>2</sup> welded wire lath specified in ASTM C 933. STRUCTALATH **TWIN TRAC 2.5** is an enhanced design that provides a tighter grid for greater reinforcing strength and improved embedment of the wires into the stucco matrix. Excellent for commercial construction, **TWIN TRAC 2.5** has been designed to simplify the attachment of wire lath to wood and steel studs.

### FEATURES

- Designed to simplify attachment for both wood and steel stud construction
- 17 ga. galvanized steel wire is precision welded to form 1" × 1½" openings
- Six additional secondary cold rolled longitudinal wires form a twin trac that simplifies attachment
- The 3/16" Twin Trac spacing allows the easy penetration of screws, nails, and a wide base for automatic staples
- Rolls are 38 ⅜" wide by 150 ft. long (50 square yards)
- Weight of roll is 1.14 lb/yd<sup>2</sup>
- Design promotes uniform plaster thickness
- Provides superior reinforcement and crack resistance
- Each and every cross wire is securely furred
- Hat channel furr provides for superior stucco embedment
- Longitudinal wires are cold rolled (flattened) to eliminate curvature memory
- Cold rolled (CR) process increases tensile and breaking load of wire
- Rolls out flat and stays flat
- Easy to fold around corners with clean bending lines

### DETAILS

- A 45 galvanized steel line wires, precision welded to form 1" × 1½" openings
- B Width of furring leg ¼"
- C Furring height ¼" to the underside of the cross wire
- D Furring rows spaced every 4" at edges and 3" at middle
- E Every cross wire is furred
- F Tabs are aligned with edge wire and extend ¼" beyond edge wires
- G Overall width is 38 ⅜"
- H Twin Trac for ease of attachment at 6" OC nominal

### PACKAGING

- 32 rolls per pallet
- Each roll is banded with poly strapping indicating manufacturer and IAPMO UES 2017
- English/Spanish installation instructions available

### GREEN ATTRIBUTES

- Made from 80% recycled steel – recycling conserves natural energy resources
- Conservation of steel without reducing strength
- Less metal with no loss of performance
- Compact packaging means further reduction in total carbon footprint

### Also Available:

- TWIN TRAC 2.5 - Stainless Steel T – 304/ANSI • *Special Order Only*



*All Structa Wire products are designed to reduce waste and can be used in various wall configurations to ensure a high performing, energy-efficient stucco system that meets industry standards. Our products are manufactured from recycled steel and contribute towards LEED points.*

*With our technically superior products and skilled customer service team, we're able to find solutions to your building requirements, improving the profitability of your projects.*

*Fully conforms to the requirements for stucco reinforcing as defined in UBC, IBC and IRC building codes.*

STRUCTA WIRE CORP. 1395 North Grandview Hwy, Vancouver, BC V5N 1N2 T 604-254-9868 E info@structawire.com



# TWIN TRAC 2.5

## Specification Sheet

IAPMO UES 2017 US Patent # 6,305,424, B1 7,287,356, B2 • CSI 09 22-36

Dimensions: Length = 150' and Width = 38 3/8"

50 square yards/roll

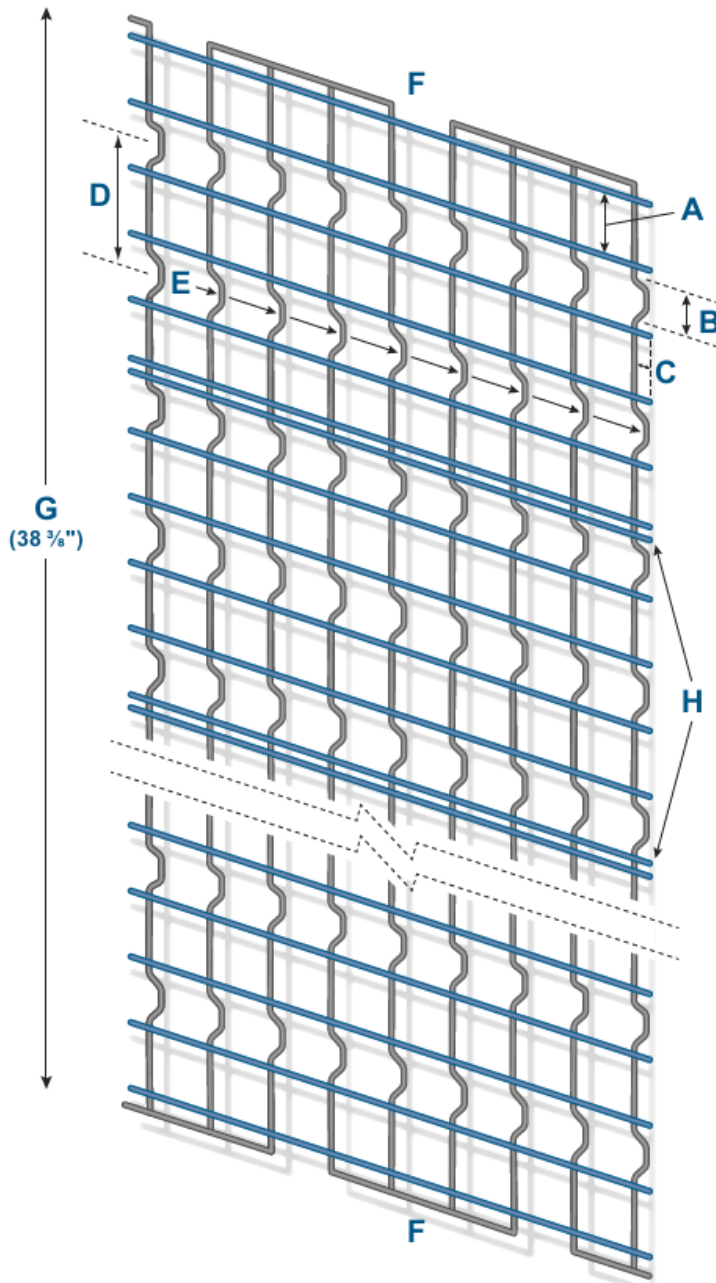

### DETAILS

- A 45 galvanized steel line wires, precision welded to form 1" x 1 1/2" openings
- B Width of furring leg 1/4"
- C Furring height 1/4" to the underside of the cross wire
- D Furring rows spaced every 4" at edges and 3" at middle
- E Every cross wire is furred
- F Tabs are aligned with edge wire and extend 1/4" beyond edge wires
- G Overall width is 38 3/8"
- H Twin Trac for ease of attachment at 6" OC nominal

Structalath products are for use as alternative laths used as reinforcement for exterior plaster complying with IBC Section 2507, IRC Section R703.6.1 or UBC Section 2508

Note: Test results are available upon request

Cold Rolled: All longitudinal wires are cold rolled to a structurally designed shape.

STRUCTA WIRE CORP. 1395 North Grandview Hwy, Vancouver, BC V5N 1N2 T 604-254-9868 E info@structawire.com

## Recommended Lapping of Structalath 1 1/2" x 38 3/8"

With any mesh, comes the challenge of wire thickness buildup at horizontal laps.

These buildups of wire can prevent the stucco from embedding the wires resulting in weak horizontal mesh lapping.

Structalath 1 1/2" x 38 3/8" is designed to minimize this buildup when installed as shown.

For best results, the guide wire of the upper width should be aligned 1/8" to 3/16" below the guide wire of the lower width (as illustrated at right).

As shown, the overall thickness of wire remains within the 1/4" furring plane.

Furthermore, the stucco locks the wires together and creates a strong horizontal lap joint that can transfer stresses from one width to the next without cracking.

**Three - 38 3/8" Structalath widths span 115 1/2" and cover a standard 9'-3" (111") wall height, including overlaps.**

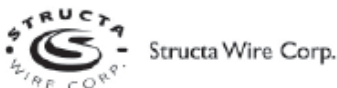
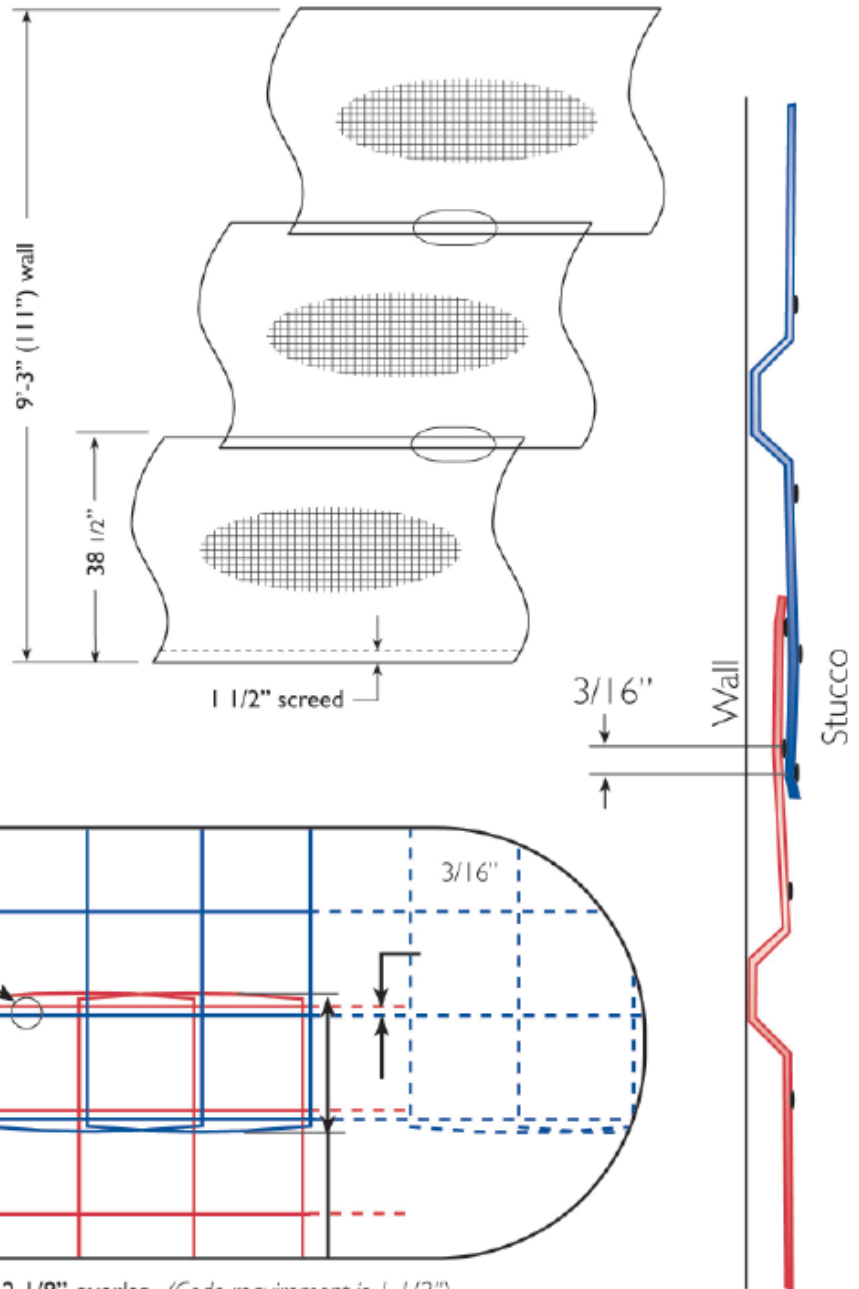

Nominal 2 1/8" overlap (Code requirement is 1 1/2")



Special Note. When screws are used for attachment they must be installed in the twin tracs' per the attachment tables contained in this manual although staples used to initially hang the wire can be placed according to this diagram.

## STRUCTAWIRE LATHS

### Attach Anywhere!

IAPMO UES 2017

The lath shall be applied to vertical surfaces having wood or metal supports. The maximum support spacing shall be 16 inches OC. Fastener type and spacing such comply with ASTM C1063 as applicable for welded wire lath except that fastener shall attach the lath to the framing supports either at the furring crimps on the vertical cross wires, at the intersection of the longitudinal wire and cross wire, or at any point along the longitudinal wire. The lath shall be lapped a minimum of one mesh at sides. Ends shall be lapped a minimum of one mesh and shall occur over supports. Additional installation requirements as set forth in an evaluation report on exterior cementitious wall coating systems shall apply as applicable. (as per ER IAPMO UES 2017)

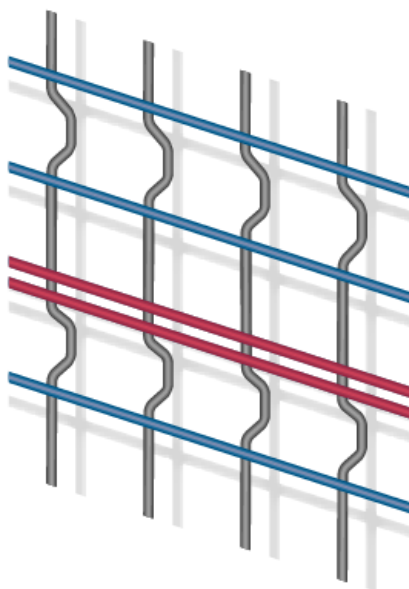

attach at the twin tracs

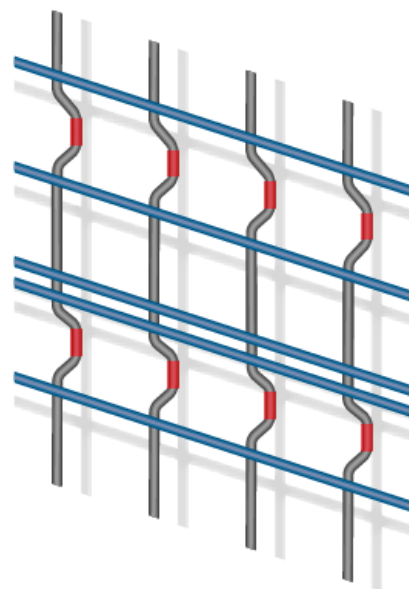

attach at the furring crimps

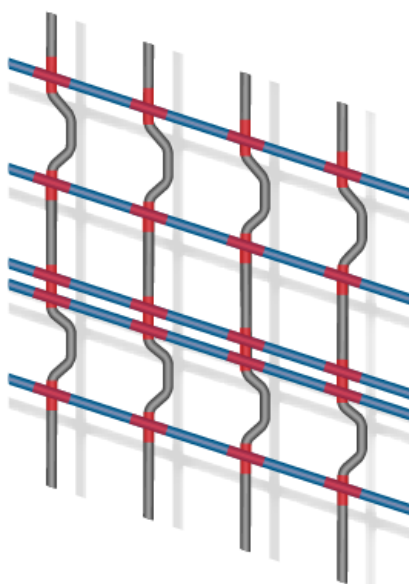

attach on the vertical cross wire at the intersection of the vertical longitudinal wire and cross wire

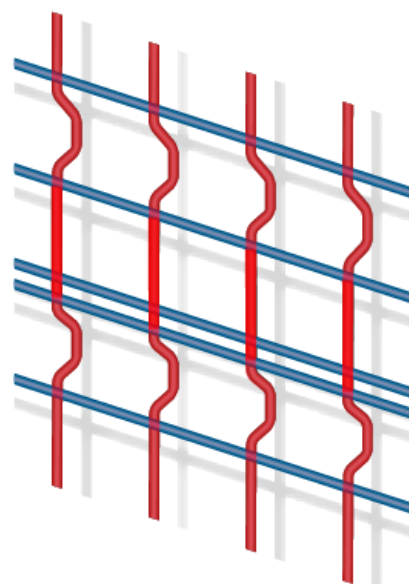

attach at any point along the longitudinal wire

# TIME & MATERIAL STUDY

## Structalath Twin Trac vs. 2.5 Diamond Lath

Time and Material analysis was calculated utilizing **On Center Quick Bid** software and compares man hours and materials required to complete projects with Diamond Lath and Structa Twin Trac as follows:

### Commercial

**Hotel Complex - Uvalde, TX**  
Metal Stud @ 24" OC over gypsum sheathing

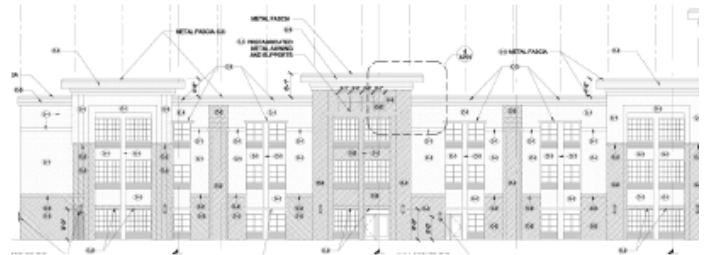

2.5 Diamond Lath	Time	Structa Twin Trac	Time
1547 sheets (27,846 sq. ft).	532 hrs	54 rolls 25,758 sq. ft.	434 hrs

**Twin Trac Material Savings: 8%**

**Twin Trac Labor Savings: 22%**

### Residential

**2 Storey Custom Home - San Antonio, TX**  
Wood Frame @ 16" OC



2.5 Diamond Lath	Time	Structa Twin Trac	Time
374 sheets (6,732 sq. ft.)	135 hrs	13 rolls 5850 sq. ft	106 hrs

**Twin Trac Material Savings: 9%**

**Twin Trac Labor Savings: 30%**

### Structa Twin Trac Designed to Improve Efficiencies

#### Labor Savings

- Less Handling – 1 roll= 25 sheets ML
- Simple Fastening at twin tracs
- Longer Lengths - at 150 ft.
- Wider Widths – at 38 3/8"
- No Wire Tying Required

#### Material Savings

- Less Vertical Overlaps  
*Twin Trac not limited to 96" lengths*
- Less Horizontal Overlaps  
*Due to 38" widths*
- Less Waste  
*Twin Trac can be custom cut to fit framing*

## DRYLOK® Extreme Basement & Masonry Waterproofer

### MANUFACTURER

#### UNITED GILSONITE LABORATORIES

**MAILING:** P.O. Box 70, Scranton, Pennsylvania, 18501

**SHIPPING:** 1396 Jefferson Avenue, Dunmore, Pennsylvania, 18509

**TOLL FREE:** 1-800-UGL-LABS (845-5227)

**PHONE:** 1-570-344-1202 • **FAX:** 1-570-969-7634

**www.UGL.com**



09 91 13 EXTERIOR PAINTING | 09 91 23 INTERIOR PAINTING

### PRODUCT DESCRIPTION

DRYLOK® Extreme Basement & Masonry Waterproofer is the Next Generation in waterproof coatings. Features Flexible Encapsulated Polymers which squeeze into the masonry for the ultimate in waterproof protection.

Specially formulated to resist mildew growth on the dry paint film. Fully transferable 15 year warranty. Reduces radon gas penetration.

- Bright white, smooth finish
- Resists mildew growth on the dry paint film
- Resists 15 PSI, equivalent to a wall of water 33 ft. high
- Category 4-resists 140 MPH wind-driven rain
- Fully transferable 15 year warranty
- Guaranteed to stop water, even under pressure
- Features flexible encapsulated polymers
- Tintable

### BASIC USES

Ideal for interior, exterior, above or below grade masonry walls, basement walls, retaining walls, foundations, landscape walls, cinder blocks, concrete blocks, bare concrete swimming pools, stucco, and brick.

### LIMITATIONS

DRYLOK® Extreme Basement & Masonry Waterproofer may be applied over previous coatings in sound condition, but the warranty is void. **Not formulated for horizontal surfaces subject to foot traffic.**

### TECHNICAL DATA

#### COMPOSITION:

Latex base

#### SHEEN:

N/A

#### % WEIGHT SOLIDS:

62-64%

#### DENSITY (LBS./US GAL.):

10.13-20.2 (1.21 ± 0.02 g/L)

#### VISCOSITY:

110-120 Ku @ 77°F (25°C)

#### pH:

9.0-10

#### COLOR:

- White – ready mixed formula
- 1 ready mixed color

#### DRY TIME:

- 2 hours
  - To recoat: 3 hours
- Note:** Maximum cure and dry time will be prolonged when slightly humid and damp, cool conditions prevail.

**Note:** When painting the inside of concrete non-potable watertanks, allow to dry at least 1 week before putting into service.

#### CLEAN UP:

Warm soapy water  
Dispose of contaminated absorbent, container, and unused contents in accordance with local, state, and federal regulations.

#### COVERAGE (SQ. FT./GAL.):

**First coat:** Wet: 21 Dry: 10 mils @ 76 sq. ft./gal.

**Second coat:** Wet: 13 Dry: 7 mils @ 125 sq. ft./gal.

**Note:** Actual coverage will vary depending upon application method, surface texture, and porosity.

#### RECOMMENDED FILM THICKNESS/COAT:

21-13 wet mils/2 coats  
(533-330 microns)

#### SHELF LIFE:

5 Years unopened container

#### FREEZE/THAW:

Three cycles

#### CONTAINER SIZES:

One quart (946 mL), One gallon (3.785), and five gallon (18.9 L) containers

#### VOC

Does not exceed 100 g/L

#### TINTING





Use alkali-proof universal tinting colorants. Use only 50% of color normally recommended. Do not use more than 2 fl. oz. of colorant per gallon. (15 g/L).

#### SURFACE PREPARATION

Masonry surfaces must be clean and free from dirt, dust, grease, oil, form release compound, frost, or paint. Patch all holes or cracks with DRYLOK® Fast Plug®, a fast setting hydraulic cement, and smooth the patch evenly with the surface around it. Check the joint where the floor and wall meet and fill any breaks with DRYLOK® Fast Plug®.

**EFFLORESCENCE**, a white, powdery, crystal-like deposit visible on the masonry surface must be removed.

DRYLOK® Etch (liquid or powder) or muriatic acid, used according to manufacturer's directions, are effective efflorescence removal agents. All masonry surfaces are subject to occurrences of efflorescence.

 <p><b>DRY TIME:</b> 2 Hours Recoat 3 Hours</p>	 <p><b>CLEAN-UP:</b> Soap and Water</p>	 <p><b>COVERAGE:</b> 2 Coats Minimum</p>	 <p><b>SPREAD RATE:</b> 100 Sq. Ft./Gallon</p>
--	--	---	---



May be applied on slightly damp surfaces, but best results are obtained when applied over dry surfaces. For best waterproofing results, wait for a dry (rain-free) period.

#### WARNING

If you scrape, sand, or remove old paint, you may release lead dust. LEAD IS TOXIC. EXPOSURE TO LEAD DUST CAN CAUSE SERIOUS ILLNESS, SUCH AS BRAIN DAMAGE, ESPECIALLY IN CHILDREN. PREGNANT WOMEN SHOULD ALSO AVOID EXPOSURE. Wear a NIOSH-approved respirator to control lead exposure. Clean up carefully with a HEPA vacuum and a wet mop. Before you start, find out how to protect yourself and your family by contacting the National Lead Information Hotline at 1-800-424-LEAD or log on to [www.epa.gov/lead](http://www.epa.gov/lead).

#### APPLICATION

STIR THOROUGHLY BEFORE AND DURING APPLICATION. DO NOT THIN. Air and surface temperatures must be 50°F (10°C), or higher. Apply directly on bare masonry. Apply first coat with a roller (3/4" nap), DRYLOK® Brush, or a good quality nylon bristle brush, or sprayer. If rolled, back brush the first coat to fill any pinholes in the masonry. If brushed, work the DRYLOK® Extreme Basement & Masonry Waterproofer into the pores of the masonry, making sure to fill all pores and pinholes (see IMPORTANT). For information on spray application specifications visit [www.ugl.com](http://www.ugl.com). Apply two coats. Allow to dry 3 hours between coats. The second and subsequent coats may be applied by roller, brush, or spray.

#### IMPORTANT

If leaking is still present after two coats, it indicates that pores or pinholes are still open. After applying the second coat of DRYLOK® Extreme Basement & Masonry Waterproofer, carefully inspect the entire wall surface for any pinholes in the waterproof coating. Any affected area should be painted with an additional coat to ensure satisfactory waterproofing results. Paint these areas again.

When painting the inside of concrete swimming pools and non-potable

watertanks, allow to dry at least 1 week before putting into service.

If desired, a high quality latex paint can be applied over DRYLOK® Extreme Basement & Masonry Waterproofer after 24 hours for decorative purposes.

#### CAUTION

Vapor harmful. May affect the brain or nervous system causing dizziness, headache, or nausea. Causes eye, nose, and throat irritation. May be harmful if absorbed through skin. Harmful if swallowed.

NOTICE: Reports have associated repeated and prolonged occupational overexposure to solvents with permanent brain and nervous system damage. Intentional misuse by deliberately concentrating and inhaling the contents may be harmful or fatal.

**Use only with adequate ventilation.** Do not breathe the vapors or spray mist. Ensure fresh air entry during application and drying. If you experience eye watering, headache, or dizziness or if air monitoring demonstrates vapor/mist levels are above applicable limits, wear an appropriate, properly fitted respirator (NIOSH-approved) during and after application. Follow respirator manufacturer's directions for respirator use. Close container after each use. Do not get in eyes, on skin, or clothing. Wash thoroughly after handling.

KEEP OUT OF REACH OF CHILDREN.  
DO NOT TAKE INTERNALLY.  
KEEP FROM FREEZING.

**EYES:** In case of eye contact, immediately flush eyes with plenty of water for at least 15 minutes, call poison control center, hospital emergency room, or physician immediately.

**SKIN:** Wash affected areas with soap and water. Consult a physician if irritation persists.

**INHALATION:** If you experience difficulty breathing, leave the area to obtain fresh air. If continued difficulty is experienced, call poison control center, hospital emergency room, or physician immediately.

**INGESTION:** If swallowed, do not induce vomiting. Call poison control center, hospital emergency room, or physician immediately.

For additional health and safety information please refer to the "Safety Data Sheet".

#### SPECIFICATION

DRYLOK® EXTREME Basement & Masonry Waterproofer has been Tested to ASTM D-7088 Resistance to Hydrostatic Pressure at 15 PSI and exceeds ASTM D-6904 Resistance to Wind-Driven Rain of 140 mph.

#### LIMITED WARRANTY

**United Gilsonite Laboratories (UGL) warrants DRYLOK® Extreme Basement & Masonry Waterproofer**, when applied according to directions on a properly prepared bare masonry surface, will provide a waterproof coating for fifteen (15) years from the date of application, warranty includes subsequent owners. There are no other warranties that extend beyond this warranty. This warranty shall not apply when the waterproofer fails due to improper product application, failure to follow label directions, inadequate surface preparation, cracked structural surfaces, reoccurring efflorescence, or any conditions not foreseen by UGL. Two coats of DRYLOK® Extreme Basement & Masonry Waterproofer are required to assure warranted waterproofing. Label directions are as complete as possible, but cannot encompass all conditions, applications and/or surfaces. In the event that the coating fails, your remedy is limited to either replacement of the product purchased or refund of the purchase price. This is the exclusive remedy. For warranty fulfillment, return used product container and sales receipt to UGL, Technical Customer Service, 1396 Jefferson Ave., Dunmore, PA, 18509. **THIS LIMITED WARRANTY EXCLUDES ALL OTHER EXPRESS OR IMPLIED WARRANTIES, INCLUDING THE WARRANTIES OF MERCHANTABILITY OR FITNESS FOR A PARTICULAR USE OR PURPOSE.** UGL will in no event be liable for any incidental or consequential damages. Some States do not allow limitations on how long an implied warranty lasts or the exclusion or limitations of incident or consequential damages, so the above limitations or exclusions may not apply to you. This warranty gives you specific legal rights, and you may also have other rights which vary from State to State.

## LIMITED 15-YEAR WARRANTY

### DRYLOK® EXTREME MASONRY WATERPROOFER

United Gilsonite Laboratories (UGL®) warrants DRYLOK® Extreme Masonry Waterproofer, when applied according to directions on a properly prepared bare masonry surface, will provide a waterproof coating for fifteen (15) years from the date of application, warranty includes subsequent owners. There are no other warranties that extend beyond this warranty. This warranty shall not apply when the waterproofer fails due to improper product application, failure to follow label directions, inadequate surface preparation, cracked structural surfaces, reoccurring efflorescence or any conditions not foreseen by UGL. Two coats of DRYLOK® Extreme Masonry Waterproofer are required to ensure warranted waterproofing. Label directions are as complete as possible, but cannot encompass all conditions, applications and/or surfaces. In the event that the coating fails, your remedy is limited to either replacement of the product purchased or refund of the purchase price. This is the exclusive remedy. For warranty fulfillment, return used product container and sales receipt to UGL, Technical Customer Service, 1396 Jefferson Ave., Dunmore, PA, 18509. **THIS LIMITED WARRANTY EXCLUDES ALL OTHER EXPRESS OR IMPLIED WARRANTIES, INCLUDING THE WARRANTIES OF MERCHANTABILITY OR FITNESS FOR A PARTICULAR USE OR PURPOSE.** UGL will in no event be liable for any incidental or consequential damages. Some States do not allow limitations on how long an implied warranty lasts or the exclusion or limitations of incidental or consequential damages, so the above limitations or exclusions may not apply to you. This warranty gives you specific legal rights, and you may also have other rights which vary from State to State.



United Gilsonite Laboratories | P.O. Box 70, Scranton, PA 18501 | [www.ugl.com](http://www.ugl.com)  
Consumer Hotline 1-800-848-7253 | [info@ugl.com](mailto:info@ugl.com)

LR318

## WARRANTY CLAIM INFORMATION

(to be filled out by the customer)

Date of purchase: \_\_\_\_\_ Date of application: \_\_\_\_\_

Store where the product was purchased: \_\_\_\_\_



**NOTICE:** This is a Transferable Warranty that may be passed on to the next homeowner. For easy reference, staple your receipt to this Warranty and keep it with your important house documents.



# **DRYLOK<sup>®</sup>** **MASONRY WATERPROOFER**

## **CASE STUDY - PROFESSIONAL ALL SEASONS SENIOR LIVING CENTER**

*Naples, Florida*





## ALL SEASONS SENIOR LIVING CENTER NAPLES, FLORIDA

On September 10th, 2017, after pummeling the Keys, Hurricane Irma roared ashore in Naples, Florida, bringing blinding, horizontal, wind-driven rain, sustained winds of more than 120 mph, and 142 mph gusts.

The All Seasons Senior Living Center was directly in the path of this Category 3 storm, while in the midst of construction. The project was sizeable, comprised of 100 independent living units, 62 assisted living units, and 25 memory care suites.



According to Michael Melugin, Associate at C+TC Design Studio in Atlanta, Georgia, and the architect for the project, "All Seasons took a direct hit by the hurricane and not a drop of water got in. The building had been dried in, the exterior finishes had been applied, and DRYLOK® worked the way we expected."

## **ALL SEASONS SENIOR LIVING CENTER NAPLES, FLORIDA**

**The coating applicator on the project had a lot of experience with DRYLOK®, having used it on several South Florida projects. 'We like the DRYLOK® warranty and we get good production from it,' said the Project Manager. 'We can also single source and use DRYLOK® Fast Plug® hydraulic cement for pre-patching.'**



## ALL SEASONS SENIOR LIVING CENTER NAPLES, FLORIDA

DRYLOK® Extreme Masonry Waterproofer was chosen for its ease of use and cost effectiveness in waterproofing exterior cement finishes to meet building dry-in requirements, prior to interior construction. Additionally, DRYLOK® is a proven, long-term solution that will keep interiors dry during frequent coastal storms and hurricanes.

To quickly allow interior construction to commence after the building shell was completed, DRYLOK® was applied over the exterior cement finish and around all the openings. According to Phillip Henderson, DRYLOK® is, "Very easy to apply with minimal surface prep." He also noted, as a point of interest, that DRYLOK® was used to waterproof the inside of decorative planters on the building.





## ALL SEASONS SENIOR LIVING CENTER NAPLES, FLORIDA



The 200+ residents of the All Seasons Senior Living Center will be protected from water intrusion, the ravages of hurricanes, and all types of storms for many years to come.



Other brand name Polyurethane Sealants can be used. See manual for common brand names. Sikaflex is a fast drying sealant and is popular among applicators.

# Sikaflex<sup>®</sup>-201 US

## General Purpose Polyurethane Sealant

### Typical Product Data

Chemical base		1-C polyurethane
Color (CQP <sup>1</sup> 001-1)		White, Tan, Aluminum Gray, MB Bronze, Deep Bronze, Black, Limestone
Cure mechanism		Moisture Cured
Density (uncured)		11.8 lb/gal
Application temperature	ambient	40°F to 110°F
Skin time <sup>2</sup> (CQP 019-1)		3 hours
Curing speed (CQP 049-1)		(see diagram 1)
Shore A-hardness (CQP 023-1 / ISO 868)		38
Tensile strength (CQP 036-1 / ISO 37)		175 psi
Elongation at break (CQP 036-1 / ISO 37)		550%
Tear propagation resistance (CQP 045-1 / ISO 34)		55 lb/in
Tensile lap-shear strength (CQP 046-1)		130 psi
Service temperature		-40°F to 190°F
Movement Accommodation (ASTM C 719)		+/-35%
Shelf life (storage below 77°F (25°C))	cartridge / unipack pail / drum	12 months 6 months

<sup>1)</sup> CQP = Corporate Quality Procedure

<sup>2)</sup> 77°F (25°C) / 50% r.h.

### Description

Sikaflex<sup>®</sup>-201 US is a one-component, flexible, polyurethane-based, non-sag elastomeric sealant system capable of +/-35% joint movement. AAMA 808.3 verified for exterior perimeter sealing compounds. Meets ASTM-C920 Type S, Grade NS, Class 35.

### Product Benefits

- Excellent adhesion – bonds to a variety of substrates without primer.
- Highly elastic and durable.
- Non-staining, exceptional cut and tear resistance.
- May be painted. Pre-testing is essential.
- Good resistance to weathering and aging.
- NSF registered, Proprietary Substances and Nonfood Compounds (aluminum gray, black, and white).

### Areas of Application

- Sealing interior and exterior joints, seams and gaps in many applications including HVAC, metal buildings, tanks and grain bins, window perimeters and many other industrial applications.
- Sealing of exposed and concealed joints in aluminum, steel, coated metals, wood and other substrates.

This product is suitable for experienced professional users only. Tests with actual substrates and conditions have to be performed to ensure adhesion and material compatibility.

**Cure Mechanism**

Sikaflex®-201 US cures by reaction with atmospheric moisture. At low temperatures the water content of the air is generally lower and the reaction proceeds more slowly. (See Diagram 1)

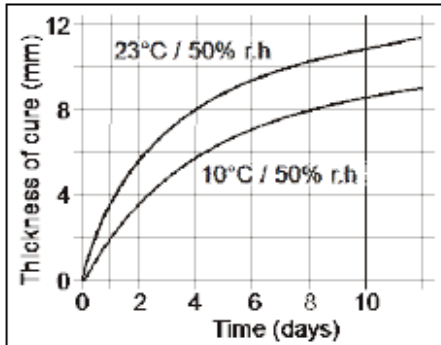

Diagram 1: Curing speed Sikaflex®-201 US

**Chemical Resistance**

Sikaflex®-201 US is resistant to fresh water, seawater, limewater, sewage effluent, dilute acids and dilute caustic solutions; temporarily resistant to fuels, mineral oils, vegetable and animal fats and oils; not resistant to organic acids, alcohol, concentrated mineral acids, concentrated caustic solutions or solvents. The above information is offered for general guidance only.

**Method of Application***Surface preparation*

Surfaces must be clean, dry and free from all traces of grease, oil and dust. As a rule, the substrates must be prepared in accordance with the instructions given in the current Sika Pre-Treatment Chart for Polyurethanes available at [www.sikausa.com](http://www.sikausa.com).

*Application*

Recommended application temperature is 40°F to 110°F. For cold weather application, store units at approximately 70°F; remove just prior to using. Make sure joint is frost-free.

*Tooling and finishing*

Tooling and finishing must be carried out within the skin time of the sealant. To facilitate tooling, wet pointing tool or finger with Sika Slick®. Do not use alcohol or alcohol-containing products.

*Removal*

Uncured Sikaflex®-201 US can be removed from tools and equipment with Sika® Remover-208 or another suitable solvent. Once cured, the material can only be removed mechanically. Hands and exposed skin should be washed immediately using a suitable industrial hand cleaner and water. Strictly follow solvent manufacturer's instructions for use and warnings. Do not use solvents on skin!

*Overpainting*

Sikaflex®-201 US can be overpainted when tack-free. The paint and paint process must be tested for compatibility by carrying out preliminary trials. Sikaflex®-201 US should not be exposed to baking temperatures until it has attained full cure. The hardness and film thickness of the paint may impair the elasticity of the sealant and lead to cracking of the paint film with time.

**Further Information**

Advice on specific applications will be given on request. To contact Sika Corporation's Industry Technical or Systems Engineering Departments please send an email to [tsmh@us.sika.com](mailto:tsmh@us.sika.com). Copies of the following publications are available on our website [www.sikausa.com](http://www.sikausa.com):

- Safety Data Sheets
- Product Data Sheets
- Sika® Pre-Treatment Chart for Polyurethanes

**Packaging Information**

Cartridge	300 ml
Unipack	600 ml
Pail	4.5 gal
Drums	50 gal

**Basis of Product Data**

All technical data stated in this Product Data Sheet are based on laboratory tests. Actual measured data may vary due to circumstances beyond our control.

**Health and Safety Information**

For information and advice regarding transportation, handling, storage and disposal of chemical products, users shall refer to the actual Safety Data Sheets containing physical, ecological, toxicological and other safety-related data

**Limited Material Warranty**

SIKA warrants this product for one year from date of installation to be free from manufacturing defects and to meet the technical properties on the current Product Data Sheet if used as directed within shelf life. User determines suitability of product for intended use and assumes all risks. Buyer's sole remedy shall be limited to the purchase price or replacement of product exclusive of labor or cost of labor.

**NO OTHER WARRANTIES EXPRESS OR IMPLIED SHALL APPLY INCLUDING ANY WARRANTY OF MERCHANTABILITY OR FITNESS FOR A PARTICULAR PURPOSE. SIKA SHALL NOT BE LIABLE UNDER ANY LEGAL THEORY FOR SPECIAL OR CONSEQUENTIAL DAMAGES. SIKA SHALL NOT BE RESPONSIBLE FOR THE USE OF THIS PRODUCT IN A MANNER TO INFRINGE ON ANY PATENT OR ANY OTHER INTELLECTUAL PROPERTY RIGHTS HELD BY OTHERS.**